

# ATF 130G-5

130 TON MAX. LIFTING CAPACITY

EUROMOT 4

# ALL TERRAIN CRANE



# Table of contents · Inhaltsverzeichnis · Table des matières Índice · Sommario · Оглавление

## General · Allgemein · Généralités · Generalidades · Generalità · Общие положения

Boom systems · Auslegersysteme · Systèmes de flèche · Sistema de pluma · Sistemi di bracci · Конфигурации стрелы 4 - 5

Vehicle dimensions · Fahrzeugabmessungen · Dimensions du véhicule · Dimensiones del vehículo  
Dimensioni veicolo · Габариты машины 6

## On-road and off-road driving · Straßen- und Geländefahrt · Marche route et tout terrain Traslado por carretera y todoterreno · Marcia su strada e fuori strada · Движение по дорогам и бездорожью

Axle loads · Achslasten · Charges par essieu · Cargas por eje · Carichi assiali · Нагрузка на ось 8

Speeds and gradeability · Geschwindigkeiten und Steigfähigkeit · Vitesses de conduite et gravissement de pente  
Velocidades y pendientes superables · Velocità e pendenza · Скорость и грузоподъемность 8

Steering · Lenkung · Direction · Dirección · Sterzo · Рулевое управление 8

## Transport · Transporte · Trasporto · Транспортировка

Counterweight · Gegengewicht · Contrepoids · Contrapeso · Contrappeso · Противовес 10 - 11

Jibs · Spitzen · Fléchettes · Plumines · Punte · гусек 12 - 13

Hose drum for hydraulic jib · Schlauchtrommel für hydraulische Spitze · Tambour de flexible pour fléchette hydraulique  
Devanadera para plumín hidráulico · Aspo raccoglitorbo per punta idraulica · Барабан для намотки шланга для гидравлического гуська 14

Auxiliary winch · Zusatzhubwinde · Treuil supplémentaire · Cabrestante auxiliar  
Argano aggiuntivo · Дополнительная лебедка 14

## Operation · Einsatz · Utilisation · Uso · Эксплуатация

Main boom · Hauptausleger · Flèche principale · Pluma principal · Braccio principale · Главная стрела 16

Swing mechanism · Drehwerk · Groupe de rotation · Mecanismo de giro · Gruppo di rotazione · Поворотный механизм 16

Winches · Hubwinden · Treuils · Cabrestantes · Argani · Лебедки 16

Hook blocks · Unterflaschen · Mouflas · Pastecas de carga · Bozzelli · Крюковые обоймы 16

Working ranges and lifting capacities · Arbeitsbereiche und Traglasten · Rayons de travail et charges de levage  
Áreas de trabajo y cargas · Aree di lavoro e portate · Рабочие зоны и грузоподъемность 18 - 41

## Equipment · Ausstattung · Équipement · Equipamiento · Equipaggiamento · Оборудование

Equipment · Ausstattung · Équipement · Equipamiento · Equipaggiamento · Оборудование 44 - 50

## Additional information · Zusatzinformationen · Informations supplémentaires Información adicional · Altre informazioni · Дополнительная информация

Remarks · Anmerkungen · Remarques · Notas · Annotazioni · Примечания 52 - 53

Symbols · Symbolerklärung · Glossaire des symboles · Glosario de simbolos  
Spiegazione dei simboli · Условные обозначения 54

# GENERAL TECHNICAL DATA

ALLGEMEINE TECHNISCHE DATEN

CARACTÉRISTIQUES TECHNIQUES GÉNÉRALES

DATOS TÉCNICOS GENERALES

DATI TECNICI GENERALI

ОБЩИЕ ТЕХНИЧЕСКИЕ ХАРАКТЕРИСТИКИ



General · Allgemein · Généralités  
 Generalidades · Generalità · Общие положения

Boom systems · Auslegersysteme · Systèmes de flèche  
 Sistema de pluma · Sistemi di bracci · Конфигурации стрелы

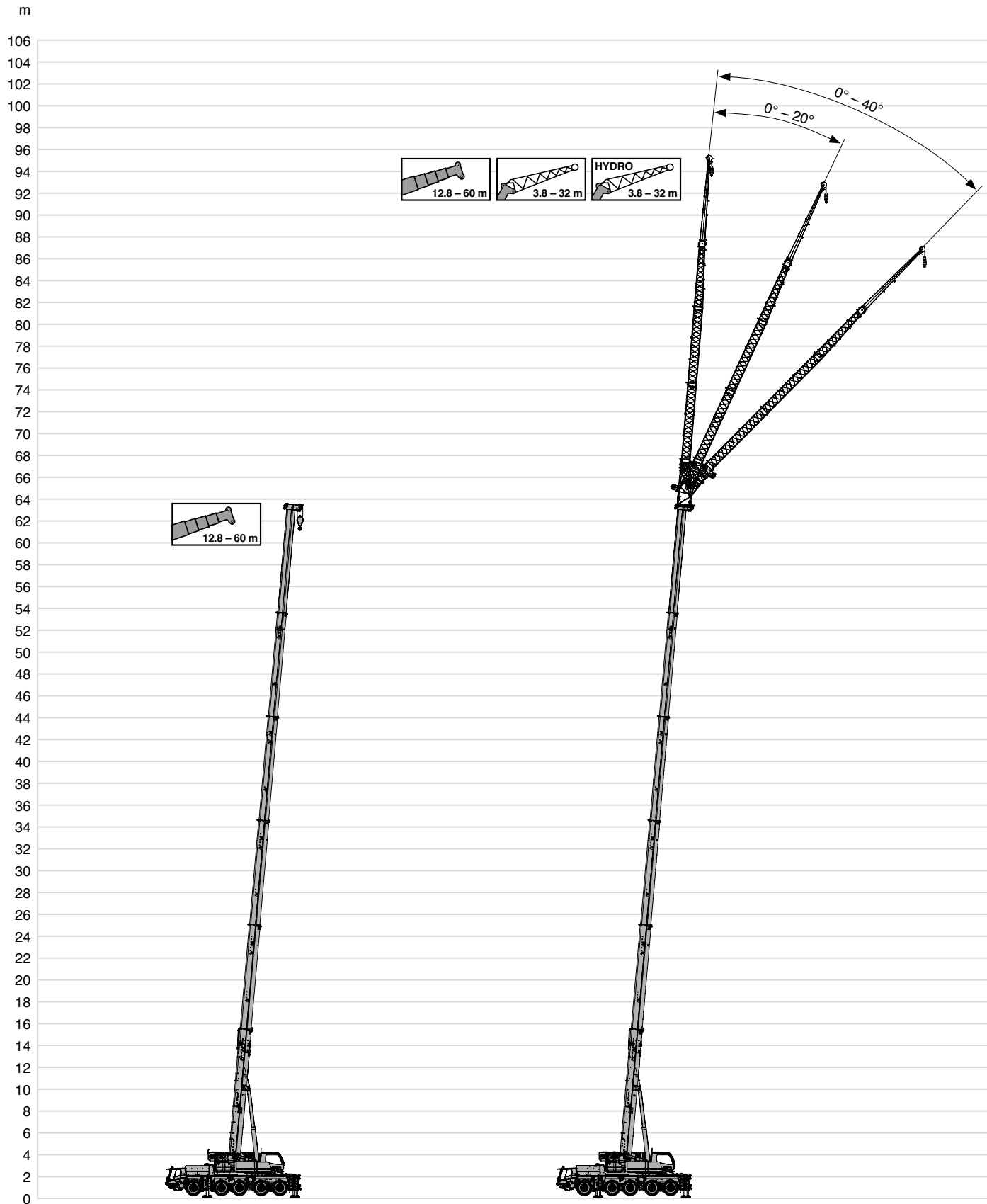

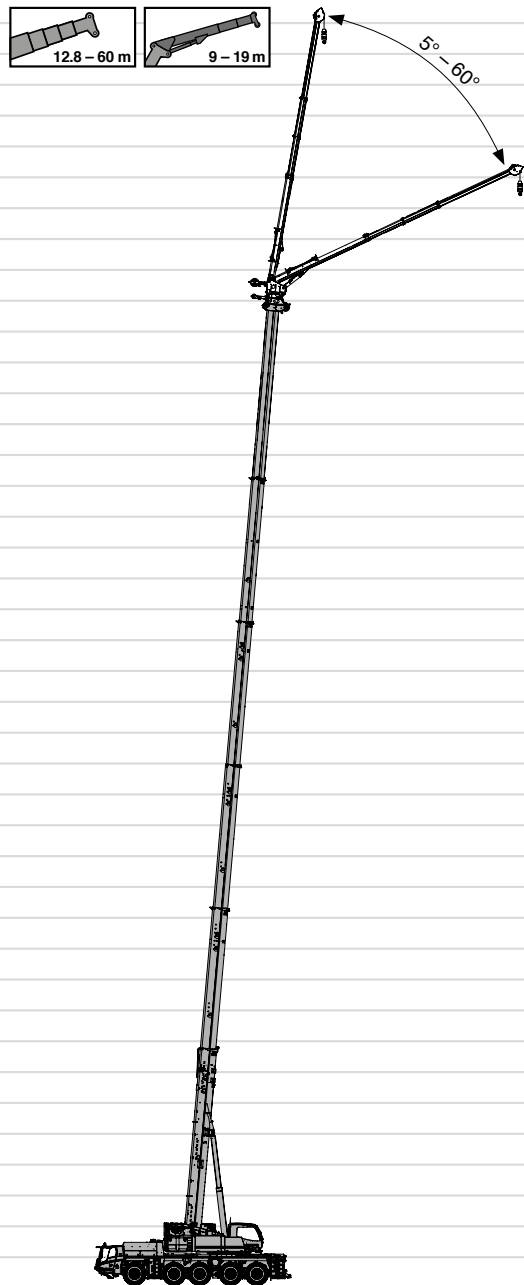

m

106

104

102

100

98

96

94

92

90

88

86

84

82

80

78

76

74

72

70

68

66

64

62

60

58

56

54

52

50

48

46

44

42

40

38

36

34

32

30

28

26

24

22

20

18

16

14

12

10

8

6

4

2

0





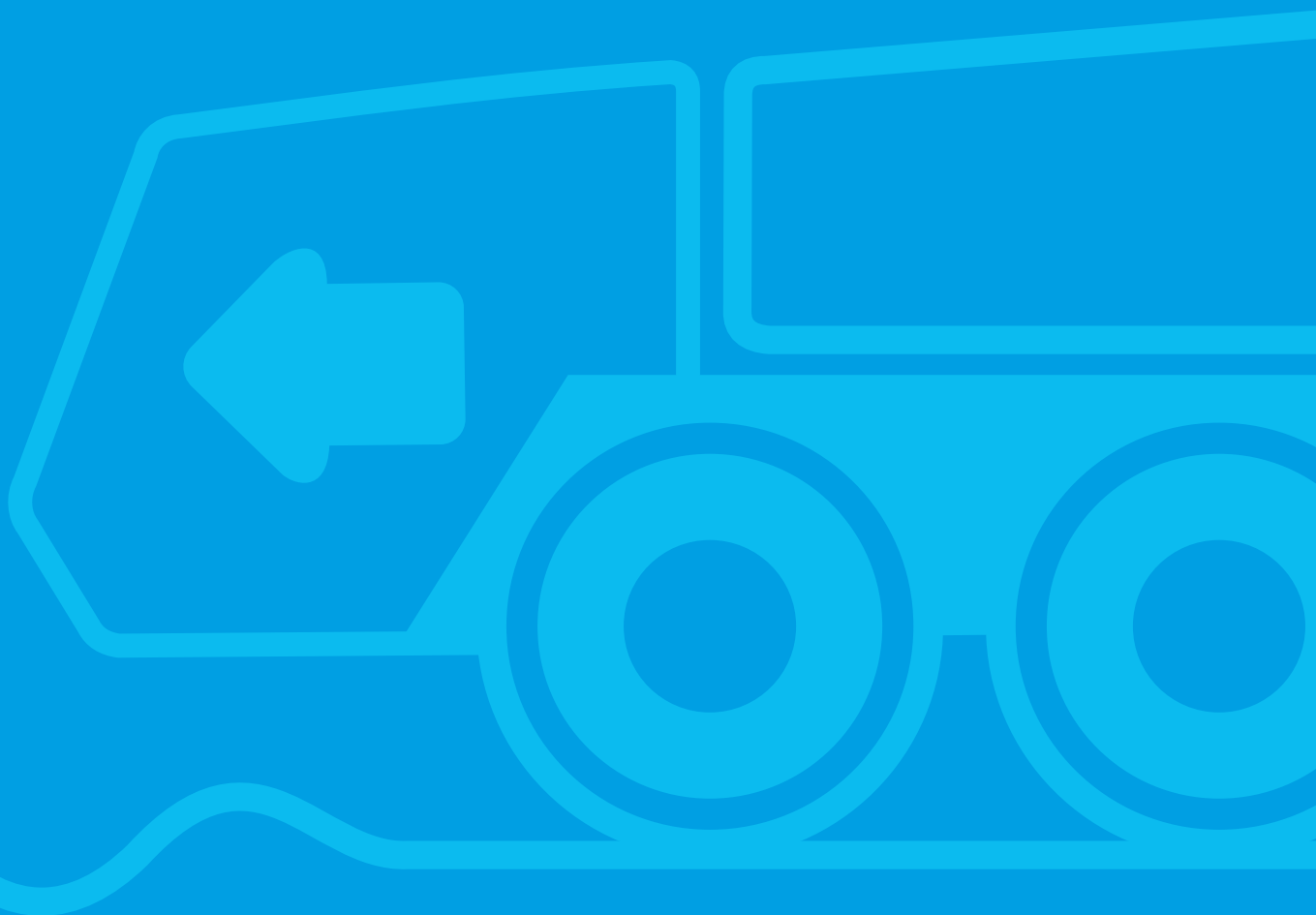

# TECHNICAL DATA FOR ON-ROAD AND OFF-ROAD DRIVING

TECHNISCHE DATEN FÜR DIE STRASSEN- UND GELÄNDEFAHRT  
CARACTÉRISTIQUES TECHNIQUES POUR MARCHE ROUTE ET TOUT TERRAIN  
DATOS TÉCNICOS PARA SU TRASLADO POR CARRETERA Y TODO TERRENO  
DATI TECNICI PER MARCIA SU STRADA E FUORI STRADA  
ТЕХНИЧЕСКИЕ ХАРАКТЕРИСТИКИ ПРИ ДВИЖЕНИИ ПО ДОРОГАМ И БЕЗДОРОЖЬЮ



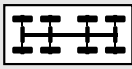

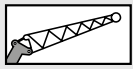





On-road and off-road driving · Straßen- und Geländefahrt · Marche route et tout terrain  
 Traslado por carretera y todoterreno · Marcia su strada e fuori strada  
 Движение по дорогам и бездорожью

Axle loads · Achslasten · Charges par essieu  
 Cargas por eje · Carichi assiali · Нагрузка на ось





	TOTAL			TYPE 		
< 11.45 t	< 57 t ***	10 x 8	525/95 R 25	63	1 m + 17 m	2.9 t
< 12 t	< 60 t ***	10 x 8	445/95 R 25	63 / 10	1 m + 17 m	6 t
< 12 t	< 60 t ***	10 x 8	445/95 R 25	63	-	8.3 t
< 13 t	< 64 t ***	10 x 8	445/95 R 25	63 / 10	1 m + 17 m	10 t
< 16.5 t	< 75.5 t ***	10 x 8	445/95 R 25	63 / 10	1 m + 17 m	21.8 t
max **	97 t ***	10 x 8	445/95 R 25	32 / 10	1 m + 31 m	42.4 t

\* Axle loads vary depending on equipment mounted. Individual calculation available on demand. · Achslasten variieren je nach Ausrüstungsumfang. Individuelle Berechnung auf Anfrage.  
 Las cargas por ejes pueden variar según el equipamiento. Cálculo individual sobre pedido. · Les charges par essieux peuvent varier en fonction de l'équipement monté. Calcul individuel sur demande.  
 I carichi degli assi variano in base all'entità dell'equipaggiamento. Calcolo individuale su richiesta. · Нагрузка на оси зависит от установленного оборудования. Индивидуальный расчет по запросу.  
 \*\* Construction site · Baustelle · Chantier de construction · Obra · Cantiere · стройплощадка  
 \*\*\* Incl. second winch or balancing weight · Inklusive zweite Winde oder Ausgleichsgewicht · Y compris deuxième treuil ou contrepoids d'équilibre  
 Incl. segundo cabrestante o peso de compensación · Incluso secondo argano o contrappeso · Включая вторую лебёдку или противовес

Speeds and gradeability · Geschwindigkeiten und Steigfähigkeit · Vitesses de conduite et gravissement de pente  
 Velocidades y pendientes superables · Velocità e pendenza · Скорость и грузоподъемность

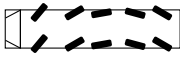
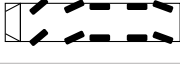
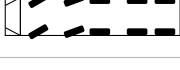
	 	 	 	 
385/95 R 25	85 km/h max.	38 km/h max.	53 %	72 %
445/95 R 25 525/80 R 25	85 km/h max.	41 km/h max.	48 %	63 %

Steering · Lenkung · Direction  
 Dirección · Sterzo · Рулевое управление

	 v < 25 km/h
	 25 km/h ≤ v ≤ 50 km/h
	 v > 50 km/h
	 Manual steering · Manuelle Lenkung · Direction manuelle Dirección manual · Sterzo manuale · Ручное управление
	 Smallest turning circle · Kleinster Wendekreis · Rayon de braquage mini. Mínimo radio · Raggio di sterzata minimo · Минимальный радиус поворота
	 Diagonal steering · Hundegang · Marche en crabe Marcha cangrejo · Sterzatura carrello · Движение по диагонали
	 Rear veering suppression · Heck-Ausscher-Unterdrückung Suppression de déboîtement AR · Supresión de movimiento transversal de parte posterior Soppressione oscillazione coda veicolo · Компенсация выноса задней части крана



# TECHNICAL DATA FOR TRANSPORT

TECHNISCHE DATEN FÜR DEN TRANSPORT  
CARACTÉRISTIQUES TECHNIQUES POUR LE TRANSPORT  
DATOS TÉCNICOS PARA EL TRANSPORTE  
DATI TECNICI PER IL TRASPORTO  
ТЕХНИЧЕСКИЕ ДАННЫЕ ДЛЯ ТРАНСПОРТИРОВКИ

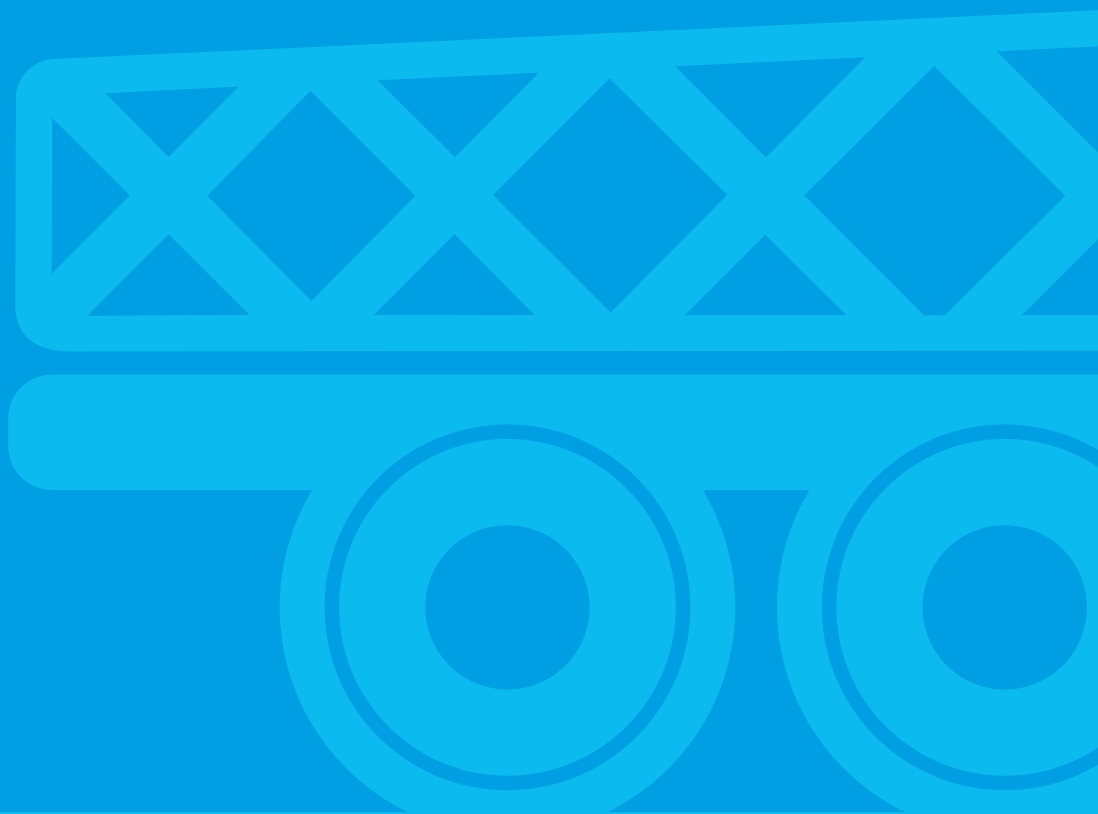

Transport · Transporte  
 Trasporto · Транспортировка

Counterweight · Gegengewicht · Contrepoids  
 Contrapeso · Contrappeso · Противовес

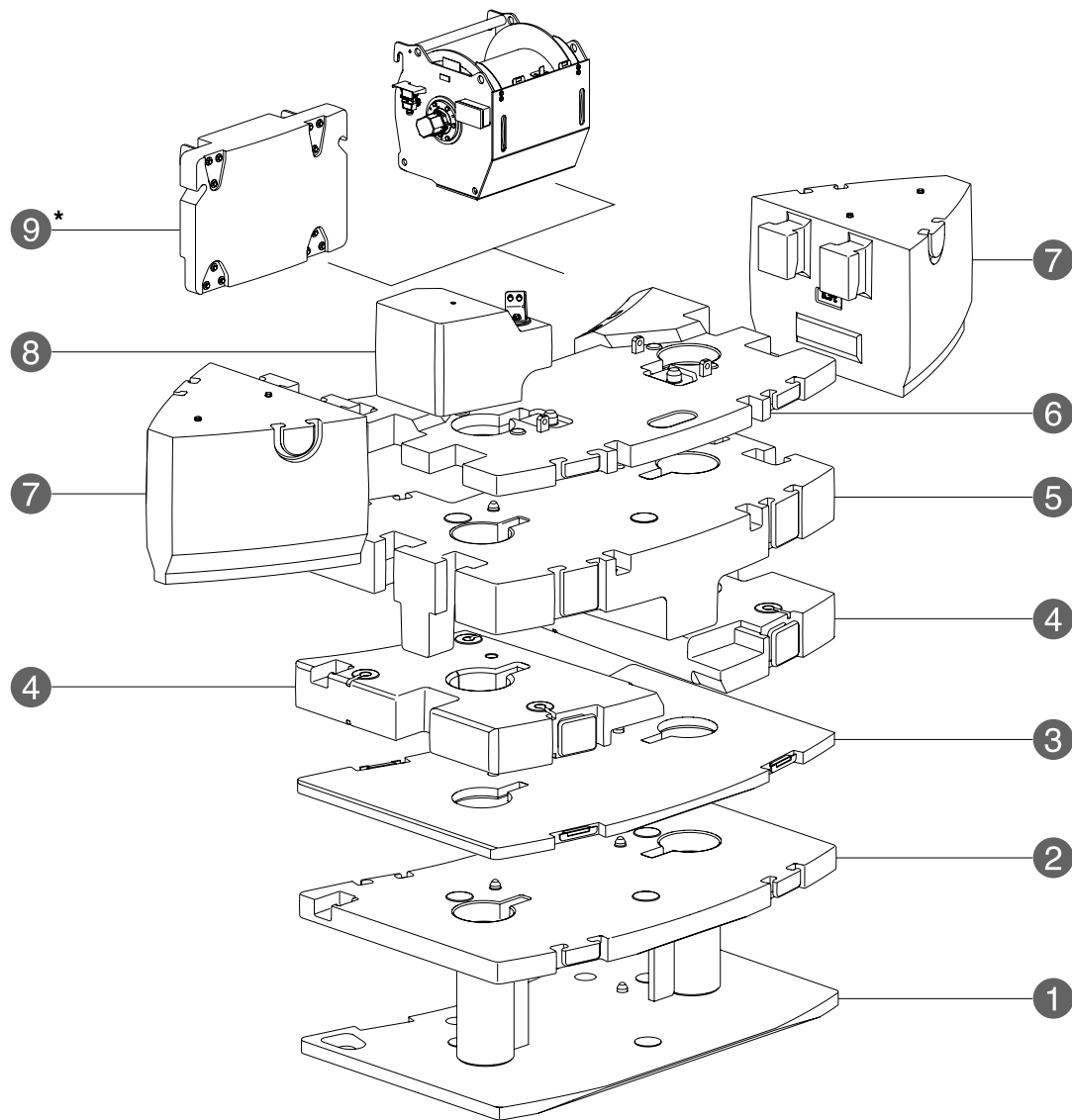

		2.9 t	6 t	8.3 t	10 t	12.3 t	15.8 t	21.8 t	24.3 t	25.8 t	31.8 t	42.4 t
①	3.1 t	-	1	1	1	1	1	1	1	1	1	1
②	4.0 t	-	-	-	1	1	1	1	-	1	1	1
③	2.3 t	-	-	1	-	1	1	1	1	1	1	1
④	3.0 t	-	-	-	-	-	-	2	2	-	2	2
⑤	10.0 t	-	-	-	-	-	-	-	1	1	1	1
⑥	3.5 t	-	-	-	-	-	1	1	-	1	1	1
⑦	5.3 t	-	-	-	-	-	-	-	-	-	-	2
⑧	1.4 t	1	1	1	1	1	1	1	1	1	1	1
⑨*	1.5 t	1	1	1	1	1	1	1	1	1	1	1

\* Can be replaced by 2<sup>nd</sup> winch · Ersetzbar durch 2. Winde · Peut être remplacé par un 2<sup>e</sup> treuil · Sostituibile per 2<sup>o</sup> cabrestante · Sostituibile con 2<sup>o</sup> argano · Возможность замены на 2-ю лебедку

1

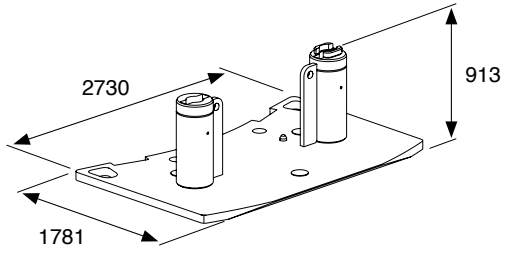

2

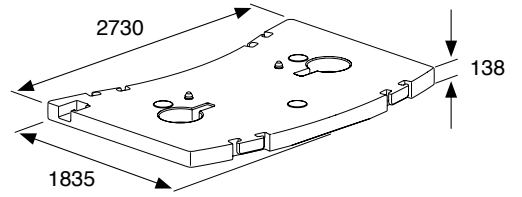

3

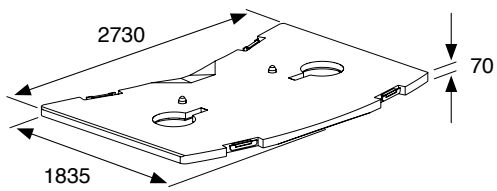

4

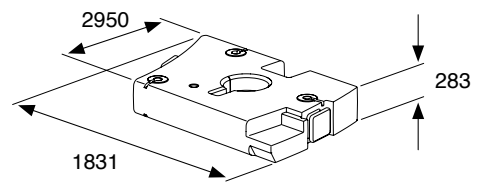

5

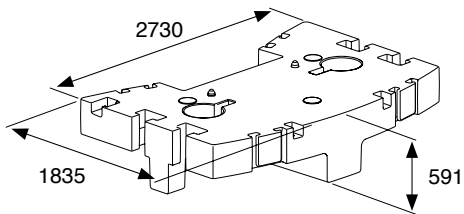

6

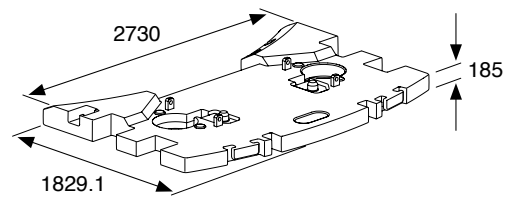

7

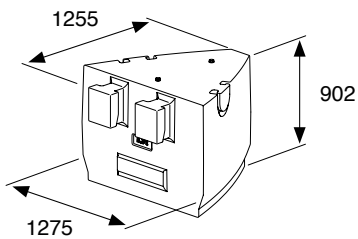

8

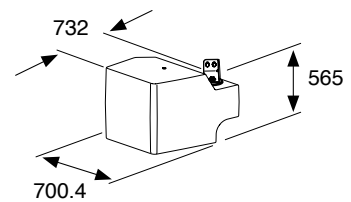

9\*

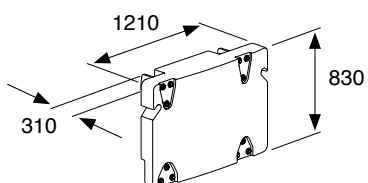

\* Can be replaced by 2<sup>nd</sup> winch · Ersetzbar durch 2. Winde · Peut être remplacé par un 2<sup>e</sup> treuil · Sustituible por 2<sup>o</sup> cabrestante · Sostituibile con 2<sup>o</sup> argano · Возможность замены на 2-ю лебедку

Transport · Transporte  
 Trasporto · Транспортировка

Jibs · Spitzen · Fléchettes  
 Plumines · Punte · гусек

 	1 m + 2.8 m	①
	1 m + 9.2 m	① + ③
	1 m + 17 m	① + ③ + ④
	1 m + 24 m	① + ② + ③ + ④
	1 m + 31 m	① + ② + ② + ③ + ④

1



860

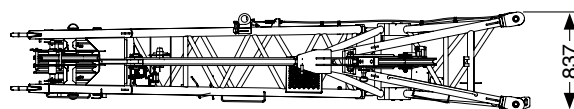
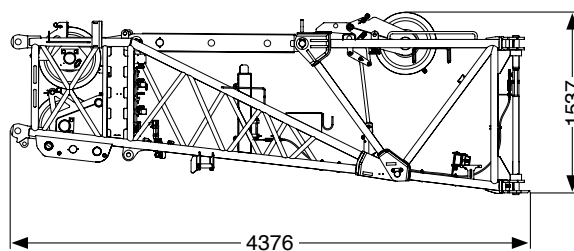

2



480

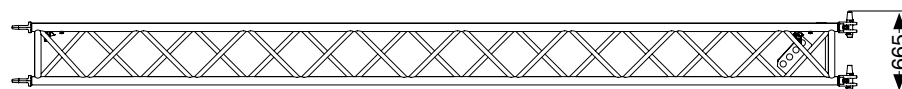
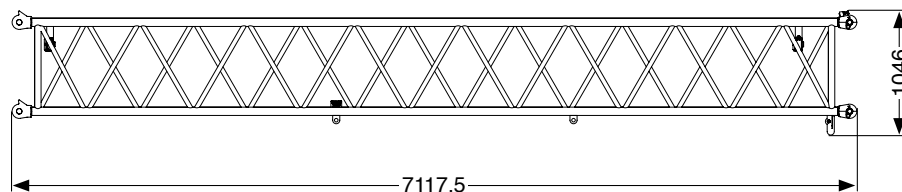

3  470

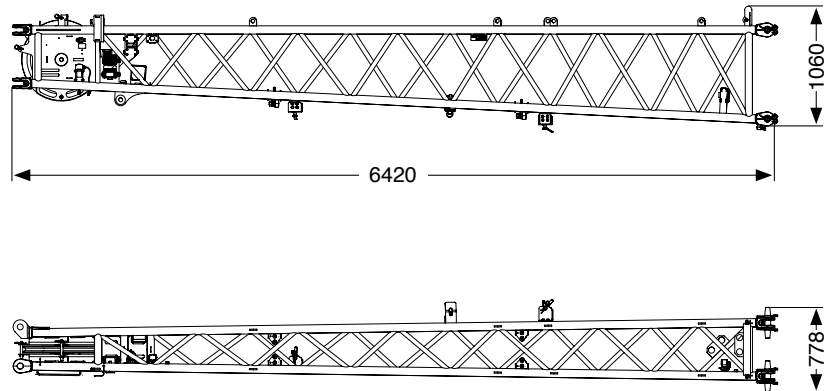

4  416

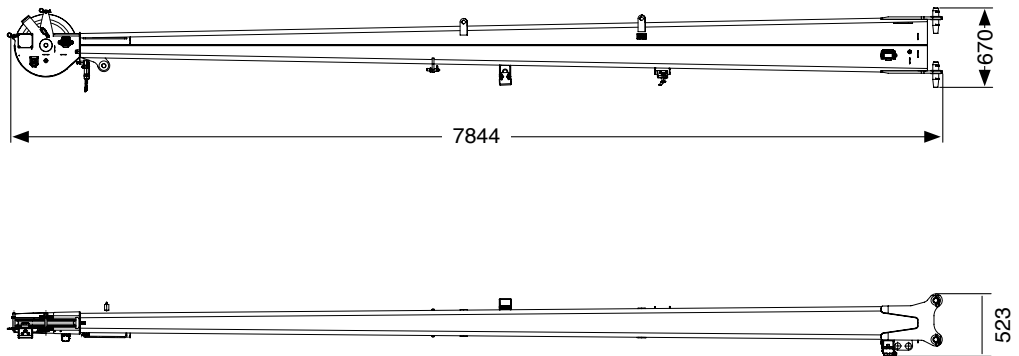

 2240

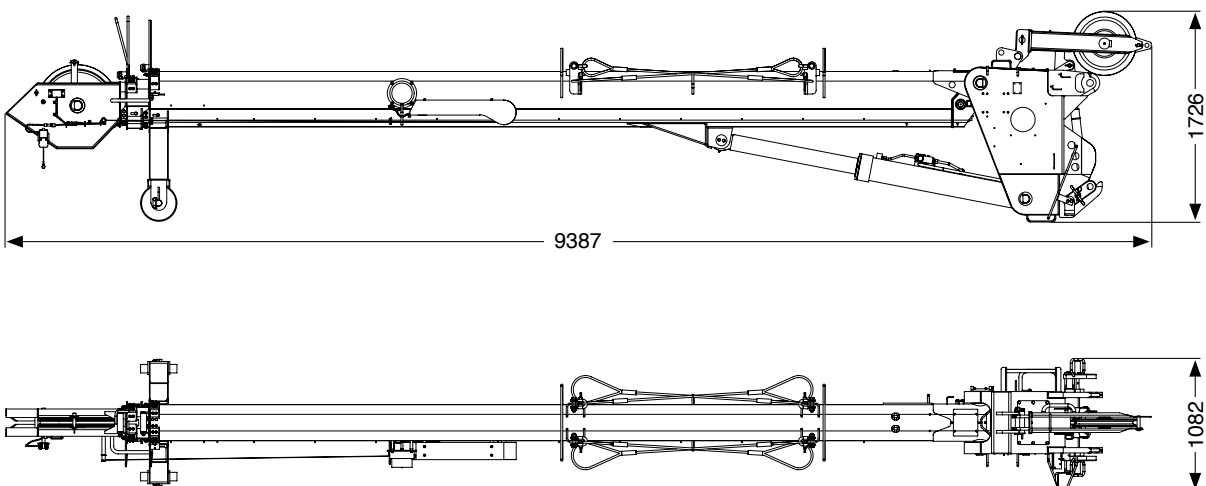

Transport · Transporte  
Trasporto · Транспортировка

Hose drum for hydraulic jib · Schlauchtrommel für hydraulische Spitze · Tambour de flexible pour flèche hydraulique  
Devanadera para plumin hidráulico · Aspo raccogli tubo per punta idraulica · Барабан для намотки шланга для гидравлического гуська



248

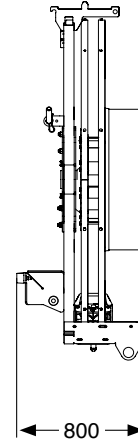
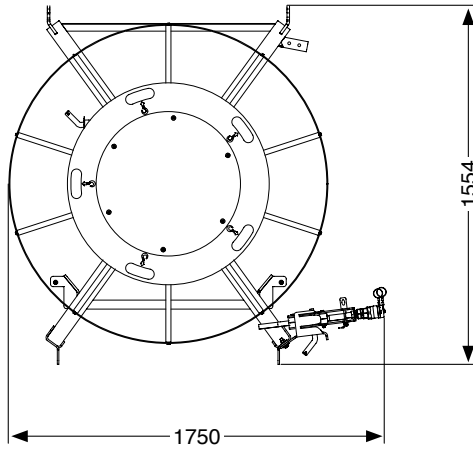

Auxiliary winch · Zusatzhubwinde · Treuil supplémentaire  
Cabrestante auxiliar · Argano aggiuntivo · Дополнительная лебедка



930/  
1475\*

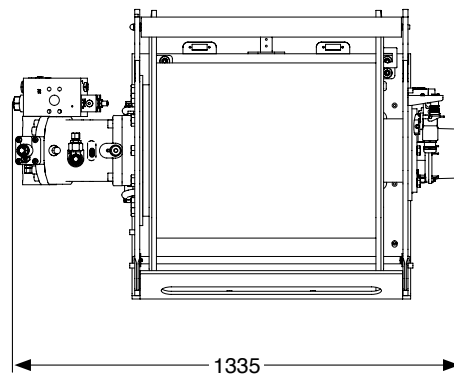
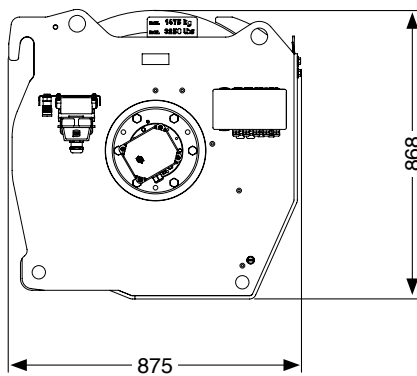

\* with rope · mit Seil · avec câble · con cable · con fune · с тросом

# TECHNICAL DATA FOR OPERATION

TECHNISCHE DATEN FÜR DEN EINSATZ

CARACTÉRISTIQUES TECHNIQUES POUR L'UTILISATION

DATOS TÉCNICOS PARA EL USO

DATI TECNICI PER L'USO

ТЕХНИЧЕСКИЕ ЭКСПЛУАТАЦИОННЫЕ ХАРАКТЕРИСТИКИ



Operation · Einsatz · Utilisation  
 Uso · Эксплуатация





Main boom · Hauptausleger · Flèche principale  
 Pluma principal · Braccio principale · Главная стрела

	- 1° – 85.4°	~ 46 s
	12.8 m – 60 m	~ 470 s





Swing mechanism · Drehwerk · Groupe de rotation  
 Mecanismo de giro · Gruppo di rotazione · Поворотный механизм

	0 – 1.6 min <sup>-1</sup>		0° / 180°
---	---------------------------	---	-----------

Winches · Hubwinden · Treuils  
 Cabrestantes · Argani · Лебедка

			
	0 – 130 m/min	21 mm / 250 m	85
	0 – 130 m/min	21 mm / 250 m	85

Hook blocks · Unterflaschen · Moufles  
 Pastecas de carga · Bozzelli · Крюковые обоймы

 TYPE				
160*	123.6	7	15	1300
100*	91.7	5	11	800
63*	59	3	7	600
63	59	3	7	600
32	25.6	1	3	450
10	8.7	-	1	300

\* Twin hook · Doppelhaken · Moufle avec crochet marin · Gancho doble · Gancio doppio · Двойной крюк



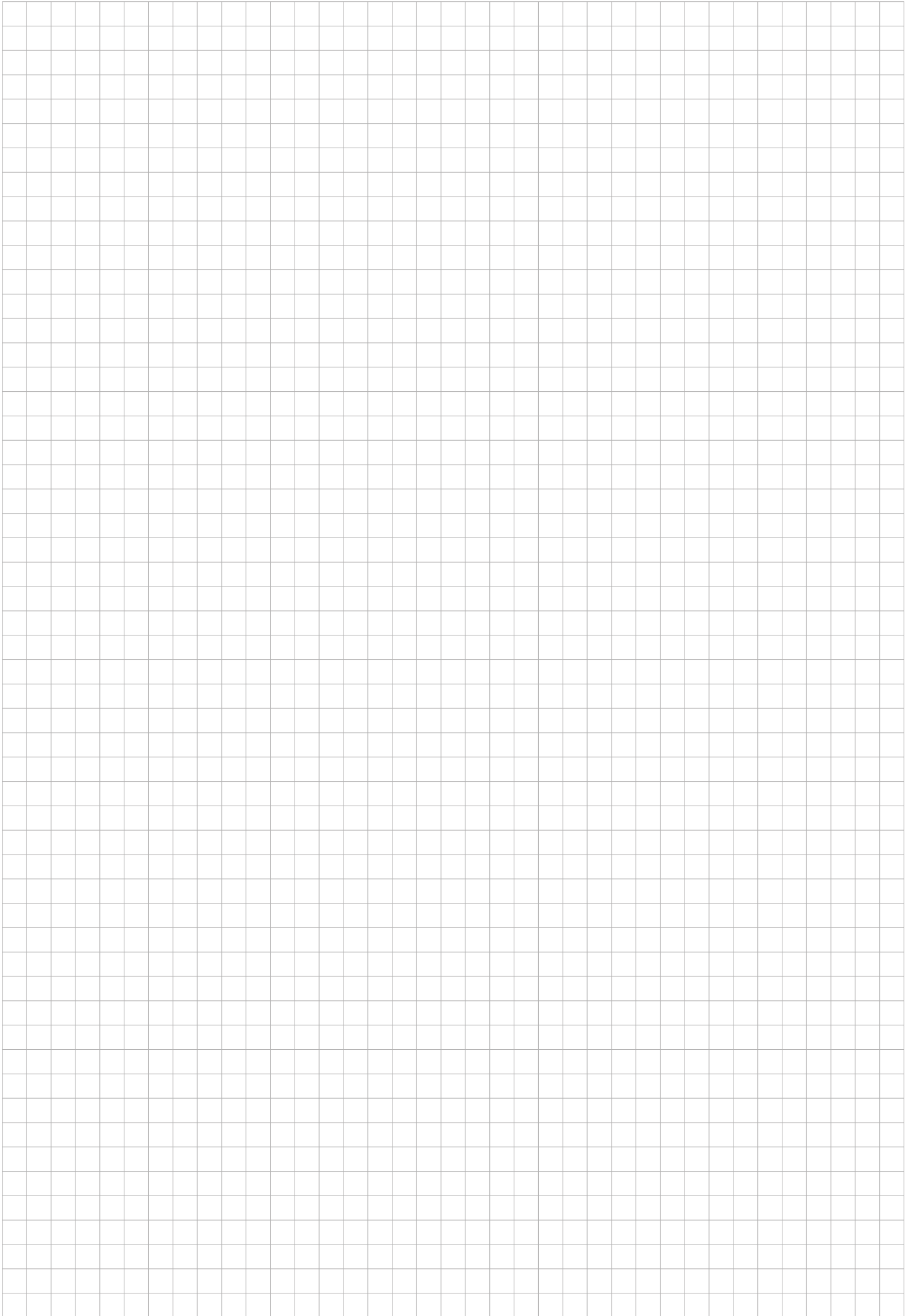

Operation · Einsatz · Utilisation  
 Uso · Эксплуатация

Working range · Arbeitsbereich · Rayon de travail  
 Zona de trabajo · Area di lavoro · Рабочая зона

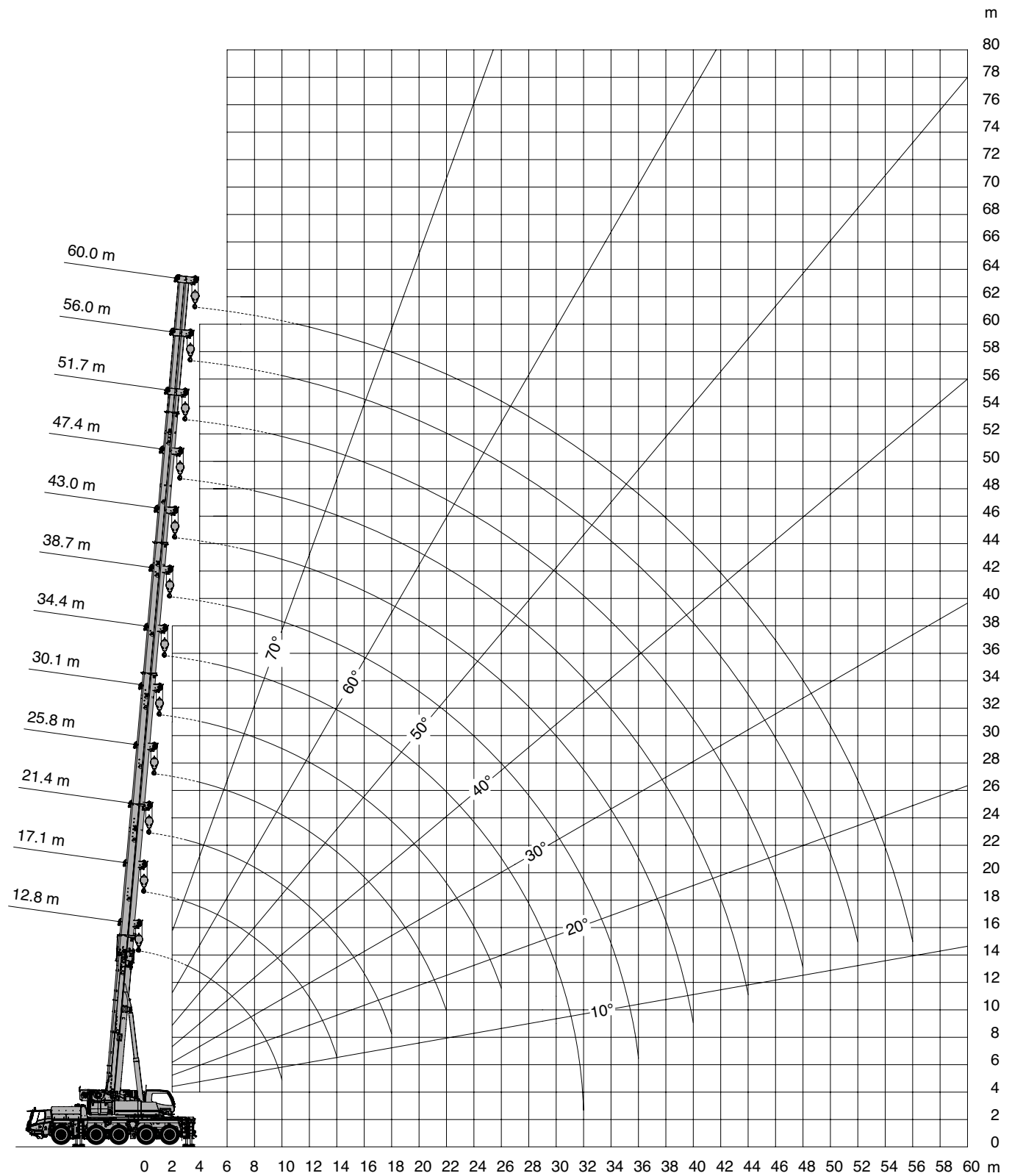



m	12.8 m*	12.8 m	17.1 m	21.4 m	25.8 m	30.1 m	34.4 m	38.7 m	43.0 m	47.4 m	51.7 m	56.0 m	60.0 m
2.7	130.0 **												
3.0	111.5 **	105.0 **	90.0	90.0									
3.5	100.9 **	96.0	90.0	90.0	70.0								
4.0	92.1	88.4	88.2	87.8	70.0								
4.5	84.7	81.8	81.6	81.3	70.0	54.3							
5.0	78.3	76.0	75.9	75.5	70.0	51.3	44.0						
6.0	67.8	66.4	66.2	65.7	66.0	50.0	42.3	32.8					
7.0	59.7	58.3	58.3	57.6	58.1	49.3	38.4	32.8	27.1				
8.0	53.1	51.4	51.7	51.4	51.2	46.0	38.0	32.8	27.1	21.4			
9.0	47.8	45.6	45.9	45.8	45.4	43.1	35.8	30.3	27.1	21.4	16.6		
10.0	42.1	40.6	41.1	41.0	40.6	40.6	33.7	28.1	26.5	21.4	16.6	13.2	
11.0			37.1	37.0	36.6	37.3	31.8	26.2	24.7	21.4	16.6	13.2	10.6
12.0			34.0	33.6	33.5	33.9	30.1	24.5	23.1	21.3	16.6	13.2	10.6
14.0			28.8	28.2	28.9	28.4	27.2	21.6	20.4	19.2	16.6	13.2	10.6
16.0				24.4	24.7	24.2	24.9	19.3	18.2	17.4	15.8	13.2	10.6
18.0				20.9	20.7	21.1	20.9	17.4	16.7	15.7	14.5	12.8	10.6
20.0					17.7	18.4	17.8	15.8	15.2	14.1	13.5	12.0	10.5
22.0					16.2	15.9	15.3	14.5	13.9	12.7	12.2	11.2	9.7
24.0						13.9	13.3	12.9	12.7	11.5	11.0	10.4	9.0
26.0						12.3	11.7	12.1	11.7	10.5	10.0	9.8	8.2
28.0							10.6	10.8	10.3	9.6	9.2	9.0	7.5
30.0							10.1	9.6	9.1	8.7	8.4	8.3	6.9
32.0							8.1	8.6	8.1	7.9	7.8	7.6	6.3
34.0								7.7	7.5	7.4	7.1	7.1	5.8
36.0								7.0	7.1	6.7	6.5	6.6	5.4
38.0									6.5	6.0	6.1	6.0	5.0
40.0									5.9	5.4	5.7	5.4	4.6
42.0										4.9	5.2	4.8	4.3
44.0										4.5	4.7	4.3	4.0
46.0											4.3	3.9	3.8
48.0											3.9	3.5	3.5
50.0												3.1	3.1
52.0												2.8	2.7
54.0													2.4
56.0													2.2

\* Over rear · Nach hinten · A l'arrière · Hacia atrás · Indietro · Назад

\*\* With additional lifting equipment · Mit Zusatzhubausrüstung · Avec équipement de levage supplémentaire

Con equipamiento de elevación adicional · Con attrezzaggio di sollevamento supplementare · С дополнительным подъемным оборудованием

Operation · Einsatz · Utilisation  
 Uso · Эксплуатация



→ m	12.8 m*	12.8 m	17.1 m	21.4 m	25.8 m	30.1 m	34.4 m	38.7 m	43.0 m	47.4 m	51.7 m	56.0 m	60.0 m
2.7	130.0 **												
3.0	109.4 **	104.0 **	90.0	90.0									
3.5	99.0	95.1	90.0	90.0	70.0								
4.0	90.4	87.5	87.4	87.0	70.0								
4.5	83.1	81.0	80.9	80.5	70.0	54.3							
5.0	76.8	75.0	74.8	74.4	70.0	51.3	44.0						
6.0	66.5	64.7	64.5	63.9	64.5	50.0	42.3	32.8					
7.0	58.5	55.9	56.2	55.8	55.6	49.3	38.4	32.8	27.1				
8.0	52.1	48.9	49.2	49.1	48.6	46.0	38.0	32.8	27.1	21.4			
9.0	46.8	43.2	43.5	43.4	43.0	43.1	35.8	30.3	27.1	21.4	16.6		
10.0	42.1	38.6	38.9	38.8	38.3	39.1	33.7	28.1	26.5	21.4	16.6	13.2	
11.0			35.5	34.9	35.4	35.2	31.8	26.2	24.7	21.4	16.6	13.2	10.6
12.0			31.8	31.1	32.1	31.4	30.1	24.5	23.1	21.3	16.6	13.2	10.6
14.0			25.1	25.5	25.3	25.4	25.4	21.6	20.4	19.2	16.6	13.2	10.6
16.0				20.8	20.8	21.3	20.7	19.3	18.2	17.4	15.8	13.2	10.6
18.0				18.0	18.1	17.8	17.2	16.6	16.7	15.7	14.5	12.8	10.6
20.0					15.3	15.1	14.4	14.7	14.5	14.1	13.5	12.0	10.5
22.0					13.1	12.9	12.6	12.8	12.3	11.9	12.2	11.2	9.7
24.0						11.1	11.6	11.1	10.6	10.9	10.5	10.4	9.0
26.0						9.7	10.2	9.6	9.8	9.4	9.4	9.4	8.2
28.0							9.0	8.4	8.7	8.2	8.6	8.2	7.5
30.0							7.9	7.7	7.6	7.3	7.6	7.1	6.9
32.0							7.1	7.3	6.8	6.7	6.7	6.3	6.3
34.0								6.5	6.2	6.2	5.9	5.5	5.5
36.0								5.9	5.8	5.5	5.3	4.8	4.8
38.0									5.2	4.9	4.7	4.2	4.2
40.0									4.7	4.4	4.1	3.7	3.7
42.0										4.0	3.7	3.2	3.2
44.0										3.5	3.2	2.8	2.8
46.0											2.9	2.4	2.4
48.0											2.5	2.1	2.1
50.0												1.8	1.8
52.0												1.5	1.5
54.0													1.2
56.0													1.0



→ m	12.8 m*	12.8 m	17.1 m	21.4 m	25.8 m	30.1 m	34.4 m	38.7 m	43.0 m	47.4 m	51.7 m	56.0 m	60.0 m
2.7	120.0 **												
3.0	108.3 **	103.5 **	90.0	90.0									
3.5	98.0	94.6	90.0	90.0	70.0								
4.0	89.4	87.1	87.0	86.6	70.0								
4.5	82.2	80.2	80.0	79.6	70.0	54.3							
5.0	75.9	74.1	73.9	73.4	70.0	51.3	44.0						
6.0	65.8	63.0	63.3	62.2	62.8	50.0	42.3	32.8					
7.0	57.9	54.2	54.5	54.5	54.0	49.3	38.4	32.8	27.1				
8.0	51.5	47.3	47.6	47.6	47.1	46.0	38.0	32.8	27.1	21.4			
9.0	45.6	41.8	42.1	42.0	41.5	40.9	35.8	30.3	27.1	21.4	16.6		
10.0	37.9	37.1	38.1	37.3	37.7	35.7	33.7	28.1	26.5	21.4	16.6	13.2	
11.0			32.7	32.0	32.9	31.6	31.3	26.2	24.7	21.4	16.6	13.2	10.6
12.0			28.5	28.9	28.7	28.3	28.1	24.5	23.1	21.3	16.6	13.2	10.6
14.0			22.5	22.7	23.0	23.3	22.7	21.5	20.4	19.2	16.6	13.2	10.6
16.0				19.1	19.2	18.9	18.2	17.6	18.0	17.0	15.8	13.2	10.6
18.0				15.7	15.8	15.5	15.1	15.5	14.9	14.3	14.4	12.8	10.6
20.0					13.2	13.0	13.6	13.0	12.4	12.8	12.3	12.0	10.5
22.0					11.3	11.0	11.6	11.0	11.3	10.8	10.8	10.8	9.7
24.0						9.6	10.0	9.6	9.7	9.4	9.6	9.2	9.0
26.0						8.3	8.7	8.9	8.4	8.6	8.3	7.9	7.9
28.0							7.6	7.8	7.6	7.5	7.2	6.8	6.8
30.0							6.8	6.9	6.9	6.6	6.3	5.8	5.9
32.0							6.4	6.1	6.1	5.8	5.5	5.1	5.1
34.0								5.4	5.4	5.1	4.8	4.4	4.4
36.0								4.9	4.8	4.5	4.2	3.8	3.8
38.0									4.3	4.0	3.7	3.2	3.2
40.0									3.8	3.5	3.2	2.8	2.8
42.0										3.1	2.8	2.3	2.3
44.0										2.7	2.4	2.0	2.0
46.0											2.1	1.6	1.6
48.0											1.8	1.3	1.3
50.0												1.0	1.0

\* Over rear · Nach hinten · A l'arrière · Hacia atrás · Indietro · Hazað

\*\* With additional lifting equipment · Mit Zusatzhubausrüstung · Avec équipement de levage supplémentaire

Con equipamiento de elevación adicional · Con attrezzaggio di sollevamento supplementare · С дополнительным подъемным оборудованием

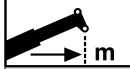

 m	12.8 m*	12.8 m	17.1 m	21.4 m	25.8 m	30.1 m	34.4 m	38.7 m	43.0 m	47.4 m	51.7 m	56.0 m	60.0 m
2.7	120.0 **												
3.0	108.0 **	103.4 **	90.0	90.0									
3.5	97.7	94.5	90.0	90.0	70.0								
4.0	89.2	87.0	86.8	86.4	70.0								
4.5	82.0	80.0	79.8	79.3	70.0	54.3							
5.0	75.7	73.8	73.6	73.1	70.0	51.3	44.0						
6.0	65.6	62.5	62.8	61.8	62.3	50.0	42.3	32.8					
7.0	57.7	53.8	54.1	54.0	53.6	49.3	38.4	32.8	27.1				
8.0	51.4	46.9	47.3	47.2	46.7	45.7	38.0	32.8	27.1	21.4			
9.0	44.2	41.4	41.7	41.6	40.2	39.3	35.8	30.3	27.1	21.4	16.6		
10.0	36.7	36.0	37.1	36.3	36.7	34.3	33.7	28.1	26.5	21.4	16.6	13.2	
11.0			31.8	32.0	32.0	30.3	30.1	26.2	24.7	21.4	16.6	13.2	10.6
12.0			27.7	28.1	27.9	28.3	26.9	24.5	23.1	21.3	16.6	13.2	10.6
14.0			22.0	22.0	22.8	22.6	21.8	20.4	19.7	19.2	16.6	13.2	10.6
16.0				18.4	18.5	18.2	17.6	17.2	17.0	16.1	15.8	13.2	10.6
18.0				15.1	15.2	14.9	14.7	14.9	14.4	13.9	13.6	12.8	10.6
20.0					12.7	12.5	13.0	12.4	12.2	12.3	11.6	11.8	10.5
22.0					10.8	10.5	11.1	10.5	10.8	10.3	10.8	10.2	9.7
24.0						9.2	9.5	9.6	9.3	9.4	9.2	8.8	8.7
26.0						7.9	8.3	8.5	8.3	8.2	8.0	7.5	7.5
28.0							7.3	7.5	7.4	7.2	6.9	6.4	6.4
30.0							6.8	6.6	6.5	6.3	6.0	5.5	5.5
32.0							6.1	5.8	5.8	5.5	5.2	4.8	4.8
34.0								5.2	5.1	4.8	4.5	4.1	4.1
36.0								4.7	4.5	4.2	3.9	3.5	3.5
38.0									4.0	3.7	3.4	3.0	3.0
40.0									3.6	3.3	3.0	2.5	2.5
42.0										2.8	2.6	2.1	2.1
44.0										2.5	2.2	1.8	1.8
46.0											1.9	1.4	1.4
48.0											1.6	1.1	1.1



 m	12.8 m*	12.8 m	17.1 m	21.4 m	25.8 m	30.1 m	34.4 m	38.7 m	43.0 m	47.4 m	51.7 m	56.0 m	60.0 m
2.7	120.0 **												
3.0	107.4 **	103.1 **	90.0	90.0									
3.5	97.3	94.3	90.0	90.0	70.0								
4.0	88.8	86.6	86.4	86.0	70.0								
4.5	81.6	79.5	79.3	78.8	70.0	54.3							
5.0	75.4	73.0	72.8	72.3	70.0	51.3	44.0						
6.0	65.3	61.7	62.0	61.2	61.5	50.0	42.3	32.8					
7.0	57.7	53.1	53.4	53.3	52.8	49.3	38.4	32.8	27.1				
8.0	51.1	46.2	46.5	46.5	45.2	43.9	38.0	32.8	27.1	21.4			
9.0	42.0	40.7	41.1	41.0	40.2	37.7	35.8	30.3	27.1	21.4	16.6		
10.0	34.8	34.2	35.3	34.4	35.2	32.9	32.5	28.1	26.5	21.4	16.6	13.2	
11.0			30.2	30.6	30.4	30.0	28.8	26.2	24.7	21.4	16.6	13.2	10.6
12.0			26.2	26.6	26.4	27.3	25.6	23.9	23.0	21.3	16.6	13.2	10.6
14.0			20.7	21.5	21.7	21.4	20.7	19.3	19.4	18.3	16.6	13.2	10.6
16.0				17.2	17.3	17.0	16.7	17.0	16.1	15.2	15.1	13.2	10.6
18.0				14.1	14.2	13.9	14.5	13.9	13.4	13.7	12.8	12.8	10.6
20.0					11.8	11.6	12.2	11.6	11.9	11.4	11.6	11.1	10.5
22.0					10.4	9.9	10.3	10.4	10.1	10.3	10.0	9.5	9.4
24.0						8.5	8.8	9.1	8.9	8.8	8.5	8.1	8.1
26.0						7.3	7.9	7.9	7.9	7.6	7.3	6.8	6.8
28.0							7.2	6.9	6.9	6.6	6.3	5.8	5.8
30.0							6.3	6.1	6.0	5.7	5.4	5.0	5.0
32.0							5.6	5.4	5.3	5.0	4.7	4.2	4.3
34.0								4.8	4.6	4.3	4.1	3.6	3.6
36.0								4.2	4.1	3.8	3.5	3.1	3.1
38.0									3.6	3.3	3.0	2.6	2.6
40.0									3.2	2.9	2.6	2.1	2.1
42.0										2.5	2.2	1.7	1.7
44.0										2.1	1.8	1.4	1.4
46.0											1.5	1.1	1.1
48.0											1.3		

\* Over rear · Nach hinten · A l'arrière · Hacia atrás · Indietro · Назад

\*\* With additional lifting equipment · Mit Zusatzhubausrüstung · Avec équipement de levage supplémentaire

Con equipamiento de elevación adicional · Con attrezzaggio di sollevamento supplementare · С дополнительным подъемным оборудованием

Operation · Einsatz · Utilisation  
 Uso · Эксплуатация



 m	12.8 m*	12.8 m	17.1 m	21.4 m	25.8 m	30.1 m	34.4 m	38.7 m	43.0 m	47.4 m	51.7 m	56.0 m	60.0 m
2.7	120.0 **												
3.0	106.3 **	102.6 **	90.0	90.0									
3.5	96.2	93.8	90.0	90.0	70.0								
4.0	87.8	85.5	85.3	84.9	70.0								
4.5	80.7	78.0	77.7	77.2	70.0	54.3							
5.0	74.5	71.0	70.8	70.2	70.0	51.3	44.0						
6.0	64.6	59.8	60.1	60.1	58.9	50.0	42.3	32.8					
7.0	56.8	51.3	51.6	51.5	47.6	45.9	38.4	32.8	27.1				
8.0	45.6	44.2	44.7	42.8	41.5	38.5	37.6	32.8	27.1	21.4			
9.0	36.6	35.8	37.1	36.7	35.5	34.2	32.3	30.0	27.1	21.4	16.6		
10.0	30.2	29.9	31.0	31.4	30.5	30.1	28.0	26.0	24.8	21.4	16.6	13.2	
11.0			26.4	26.8	27.6	26.4	24.6	22.8	22.3	21.3	16.6	13.2	10.6
12.0			23.0	23.9	24.0	23.4	21.8	20.8	20.2	18.9	16.6	13.2	10.6
14.0			17.4	18.2	18.4	18.1	17.7	17.6	16.3	16.2	15.2	13.2	10.6
16.0				14.4	14.5	14.3	14.9	14.3	14.4	13.5	13.6	12.6	10.6
18.0				11.7	12.1	11.8	12.2	12.4	11.9	12.1	11.5	10.6	10.4
20.0					10.4	9.7	10.2	10.4	10.4	10.1	9.8	9.0	8.8
22.0					8.8	8.1	9.1	8.8	8.7	8.5	8.2	7.7	7.5
24.0						7.2	7.7	7.5	7.4	7.2	6.9	6.4	6.4
26.0						6.5	6.7	6.5	6.3	6.1	5.8	5.3	5.3
28.0							5.8	5.6	5.5	5.2	4.9	4.4	4.4
30.0							5.0	4.8	4.7	4.4	4.1	3.7	3.7
32.0							4.4	4.2	4.1	3.8	3.5	3.0	3.1
34.0								3.6	3.5	3.2	2.9	2.5	2.5
36.0								3.2	3.0	2.7	2.4	2.0	2.0
38.0									2.6	2.3	2.0	1.6	1.6
40.0									2.2	1.9	1.6	1.2	1.2
42.0										1.6	1.3		
44.0										1.3	1.0		

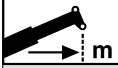

 m	12.8 m*	12.8 m	17.1 m	21.4 m	25.8 m	30.1 m	34.4 m	38.7 m	43.0 m	47.4 m	51.7 m	56.0 m	60.0 m
2.7	120.0 **												
3.0	105.6 **	102.3 **	90.0	90.0									
3.5	95.6	93.1	90.0	90.0	70.0								
4.0	87.3	84.8	84.6	84.0	70.0								
4.5	80.2	76.7	76.4	75.9	70.0	54.3							
5.0	74.1	69.7	70.1	69.0	69.6	51.3	44.0						
6.0	64.6	58.6	59.0	58.9	54.3	50.0	42.3	32.8					
7.0	54.5	50.1	50.5	47.6	45.8	42.2	38.4	32.8	27.1				
8.0	41.8	40.7	42.0	39.7	38.2	36.7	34.3	31.6	27.1	21.4			
9.0	33.4	32.9	34.1	34.3	32.1	31.6	29.2	27.0	25.7	21.4	16.6		
10.0	27.5	27.2	28.5	28.9	29.0	27.3	25.2	23.3	23.1	21.4	16.6	13.2	
11.0			24.3	25.2	25.3	23.9	22.4	21.9	20.4	19.0	16.6	13.2	10.6
12.0			20.6	21.5	21.6	21.1	19.8	19.5	18.1	17.9	16.6	13.2	10.6
14.0			15.5	16.3	16.4	16.2	16.8	15.7	15.6	14.7	14.3	13.2	10.6
16.0				12.8	13.3	12.9	13.3	13.6	12.9	12.8	12.1	11.2	10.6
18.0				10.4	11.1	10.4	11.2	11.1	11.1	10.8	10.1	9.3	9.1
20.0					9.2	8.7	9.5	9.3	9.1	8.9	8.6	7.8	7.7
22.0					7.7	7.8	8.0	7.8	7.6	7.4	7.1	6.6	6.5
24.0						6.6	6.8	6.6	6.4	6.2	5.9	5.4	5.4
26.0						5.6	5.8	5.6	5.5	5.2	4.9	4.4	4.4
28.0							5.0	4.8	4.6	4.4	4.1	3.6	3.6
30.0							4.3	4.1	3.9	3.7	3.4	2.9	2.9
32.0							3.7	3.5	3.4	3.1	2.8	2.3	2.4
34.0								3.0	2.8	2.6	2.3	1.8	1.8
36.0								2.6	2.4	2.1	1.8	1.4	1.4
38.0									2.0	1.7	1.4	1.0	1.0
40.0									1.7	1.4	1.1		
42.0										1.1			

\* Over rear · Nach hinten · A l'arrière · Hacia atrás · Indietro · Hazað

\*\* With additional lifting equipment · Mit Zusatzhubausrüstung · Avec équipement de levage supplémentaire

Con equipamiento de elevación adicional · Con attrezzaggio di sollevamento supplementare · С дополнительным подъемным оборудованием



 m	12.8 m*	12.8 m	17.1 m	21.4 m	25.8 m	30.1 m	34.4 m	38.7 m	43.0 m	47.4 m	51.7 m	56.0 m	60.0 m
2.7	120.0 **												
3.0	105.2 **	102.1 **	90.0	90.0									
3.5	95.2	92.6	90.0	90.0	70.0								
4.0	86.9	83.9	83.7	83.2	70.0								
4.5	79.8	75.8	75.6	75.0	70.0	54.3							
5.0	73.8	68.9	69.3	68.1	66.5	51.3	44.0						
6.0	63.9	57.8	58.2	56.4	51.3	48.9	42.3	32.8					
7.0	51.5	49.4	48.6	45.0	43.4	39.8	38.0	32.8	27.1				
8.0	39.4	38.4	39.8	38.4	35.7	34.8	32.0	29.5	27.1	21.4			
9.0	31.4	31.0	32.2	32.1	31.5	29.5	27.2	25.1	23.8	21.4	16.6		
10.0	25.8	25.2	26.9	27.8	27.1	25.5	23.8	23.2	21.5	20.1	16.6	13.2	
11.0			22.5	23.4	23.6	22.2	20.8	20.4	19.0	18.6	16.6	13.2	10.6
12.0			19.1	20.0	20.1	19.6	19.5	18.1	17.6	16.6	15.4	13.2	10.6
14.0			14.3	15.1	15.2	15.2	15.6	15.0	14.4	14.2	13.4	12.4	10.6
16.0				11.8	12.6	11.9	12.5	12.6	12.5	11.8	11.1	10.2	9.9
18.0				9.5	10.2	9.7	10.5	10.3	10.2	9.9	9.3	8.5	8.3
20.0					8.4	8.5	8.7	8.5	8.4	8.1	7.8	7.1	6.9
22.0					7.0	7.1	7.3	7.1	7.0	6.7	6.4	5.9	5.8
24.0						6.0	6.1	5.9	5.8	5.6	5.3	4.8	4.8
26.0						5.0	5.2	5.0	4.9	4.6	4.3	3.9	3.9
28.0							4.4	4.2	4.1	3.9	3.6	3.1	3.1
30.0							3.8	3.6	3.5	3.2	2.9	2.5	2.5
32.0							3.3	3.0	2.9	2.6	2.3	1.9	1.9
34.0								2.6	2.4	2.2	1.9	1.4	1.4
36.0								2.2	2.0	1.7	1.4	1.0	1.0
38.0									1.7	1.4	1.1		
40.0									1.3	1.0			



 m	12.8 m*	12.8 m	17.1 m	21.4 m	25.8 m	30.1 m	34.4 m	38.7 m	43.0 m	47.4 m	51.7 m	56.0 m	60.0 m
2.7	120.0 **												
3.0	104.9 **	102.0 **	90.0	90.0									
3.5	94.9	92.2	90.0	90.0	70.0								
4.0	86.6	83.2	83.0	82.5	70.0								
4.5	79.6	75.1	74.9	74.4	70.0	54.3							
5.0	73.5	68.3	68.6	67.6	63.6	51.3	44.0						
6.0	63.6	57.2	57.5	53.9	50.0	46.7	42.3	32.8					
7.0	49.1	47.3	47.4	43.2	41.3	39.6	36.4	32.8	27.1				
8.0	37.4	36.6	38.0	36.3	34.3	33.0	30.2	27.8	26.2	21.4			
9.0	29.8	29.3	30.8	30.3	29.8	27.9	26.0	24.5	23.1	21.4	16.6		
10.0	24.5	23.6	25.5	26.4	25.6	24.0	22.4	21.9	20.2	18.8	16.6	13.2	
11.0			21.2	22.1	22.2	20.9	20.6	19.2	18.6	17.5	16.3	13.2	10.6
12.0			17.9	18.8	18.9	18.5	18.5	17.0	16.8	15.7	14.4	13.2	10.6
14.0			13.3	14.1	14.8	14.2	14.6	14.6	14.1	13.3	12.6	11.6	10.6
16.0				11.0	11.8	11.0	12.1	11.8	11.7	11.0	10.3	9.5	9.2
18.0				8.8	9.5	9.6	9.8	9.6	9.5	9.2	8.6	7.8	7.6
20.0					7.8	7.9	8.1	7.9	7.8	7.5	7.2	6.5	6.3
22.0					6.5	6.5	6.7	6.5	6.4	6.1	5.8	5.4	5.2
24.0						5.5	5.6	5.4	5.3	5.1	4.8	4.3	4.3
26.0						4.6	4.8	4.6	4.4	4.2	3.9	3.4	3.4
28.0							4.0	3.8	3.7	3.4	3.1	2.7	2.7
30.0							3.4	3.2	3.1	2.8	2.5	2.1	2.1
32.0							2.9	2.7	2.6	2.3	2.0	1.5	1.6
34.0								2.2	2.1	1.8	1.5	1.1	1.1
36.0								1.9	1.7	1.4	1.1		
38.0									1.4	1.1			
40.0										1.1			

\* Over rear · Nach hinten · A l'arrière · Hacia atrás · Indietro · Назад

\*\* With additional lifting equipment · Mit Zusatzhubausrüstung · Avec équipement de levage supplémentaire

Con equipamiento de elevación adicional · Con attrezzaggio di sollevamento supplementare · С дополнительным подъемным оборудованием

Operation · Einsatz · Utilisation  
 Uso · Эксплуатация



Reach (m)	12.8 m*	12.8 m	17.1 m	21.4 m	25.8 m	30.1 m	34.4 m	38.7 m	43.0 m	47.4 m	51.7 m	56.0 m	60.0 m
2.7	120.0 **												
3.0	104.4 **	101.5 **	90.0	90.0									
3.5	94.5	91.8	90.0	90.0	70.0								
4.0	86.3	82.3	82.1	81.6	70.0								
4.5	79.2	74.3	74.5	73.5	69.9	54.3							
5.0	73.2	67.4	67.7	67.0	59.8	51.3	44.0						
6.0	60.0	56.4	55.5	50.7	48.3	43.8	39.4	32.8					
7.0	46.0	44.5	44.6	41.6	38.3	37.0	33.8	30.8	27.1				
8.0	35.0	34.4	35.6	33.7	32.9	30.6	28.4	25.7	24.2	21.4			
9.0	27.8	26.9	28.5	29.1	27.6	25.8	24.0	23.4	21.5	19.9	16.6		
10.0	22.8	21.5	23.4	24.4	23.7	22.2	21.9	20.2	19.5	18.3	16.6	13.2	
11.0			19.4	20.3	20.5	19.3	19.2	17.7	17.4	16.1	14.9	13.2	10.6
12.0			16.4	17.2	17.4	17.2	17.0	16.6	15.8	15.1	14.2	13.1	10.6
14.0			12.1	13.0	13.7	13.0	14.0	13.5	13.0	12.2	11.4	10.5	10.2
16.0				10.0	10.7	10.9	11.1	10.9	10.7	10.0	9.4	8.5	8.3
18.0				7.9	8.6	8.7	8.9	8.7	8.6	8.3	7.7	7.0	6.8
20.0					7.0	7.1	7.3	7.1	7.0	6.7	6.4	5.7	5.6
22.0					5.8	5.8	6.0	5.8	5.7	5.5	5.1	4.7	4.6
24.0						4.8	5.0	4.8	4.7	4.4	4.1	3.7	3.7
26.0						4.0	4.2	4.0	3.9	3.6	3.3	2.9	2.9
28.0							3.5	3.3	3.2	2.9	2.6	2.2	2.2
30.0							2.9	2.7	2.6	2.3	2.0	1.6	1.6
32.0							2.5	2.2	2.1	1.8	1.5	1.1	
34.0								1.8	1.7	1.4	1.1		
36.0								1.5	1.3	1.0			
38.0									1.0				



Reach (m)	12.8 m*	12.8 m	17.1 m	21.4 m	25.8 m	30.1 m	34.4 m	38.7 m	43.0 m	47.4 m	51.7 m	56.0 m	60.0 m
2.7	110.5 **												
3.0	103.6 **	100.5 **	90.0	90.0									
3.5	93.8	90.3	90.0	89.5	70.0								
4.0	85.5	80.7	80.5	80.0	70.0								
4.5	78.6	72.7	73.0	71.4	63.4	54.3							
5.0	72.6	65.9	66.2	60.9	54.2	50.0	44.0						
6.0	54.3	55.0	50.3	47.3	43.3	41.2	37.1	32.8					
7.0	41.4	40.3	39.4	36.9	35.6	32.9	30.2	27.1	25.4				
8.0	31.4	30.4	31.4	30.9	29.1	27.0	25.0	24.1	22.1	20.3			
9.0	24.8	23.3	25.4	25.7	24.4	22.7	22.4	20.5	19.7	18.4	16.6		
10.0	20.2	18.5	20.4	21.4	20.8	19.7	19.3	18.2	17.9	15.9	14.7	13.2	
11.0			16.8	17.7	17.9	17.1	16.9	16.5	15.9	14.9	13.9	12.8	10.6
12.0			14.1	15.1	15.9	15.0	15.6	14.8	14.1	13.2	12.3	11.3	10.6
14.0			10.2	11.1	11.9	12.0	12.3	11.8	11.3	10.5	9.8	8.9	8.6
16.0				8.5	9.2	9.3	9.6	9.4	9.2	8.5	7.9	7.1	6.9
18.0				6.6	7.3	7.4	7.6	7.4	7.3	7.0	6.4	5.7	5.5
20.0					5.9	5.9	6.1	6.0	5.8	5.6	5.2	4.6	4.4
22.0					4.7	4.8	5.0	4.8	4.7	4.4	4.1	3.6	3.5
24.0						3.9	4.1	3.9	3.8	3.5	3.2	2.7	2.7
26.0						3.2	3.3	3.2	3.0	2.8	2.5	2.0	2.0
28.0							2.7	2.5	2.4	2.1	1.9	1.4	
30.0							2.2	2.0	1.9	1.6	1.3		
32.0							1.8	1.6	1.4	1.2			
34.0								1.2	1.1				

\* Over rear · Nach hinten · A l'arrière · Hacia atrás · Indietro · Hazað

\*\* With additional lifting equipment · Mit Zusatzhubausrüstung · Avec équipement de levage supplémentaire

Con equipamiento de elevación adicional · Con attrezzaggio di sollevamento supplementare · С дополнительным подъемным оборудованием



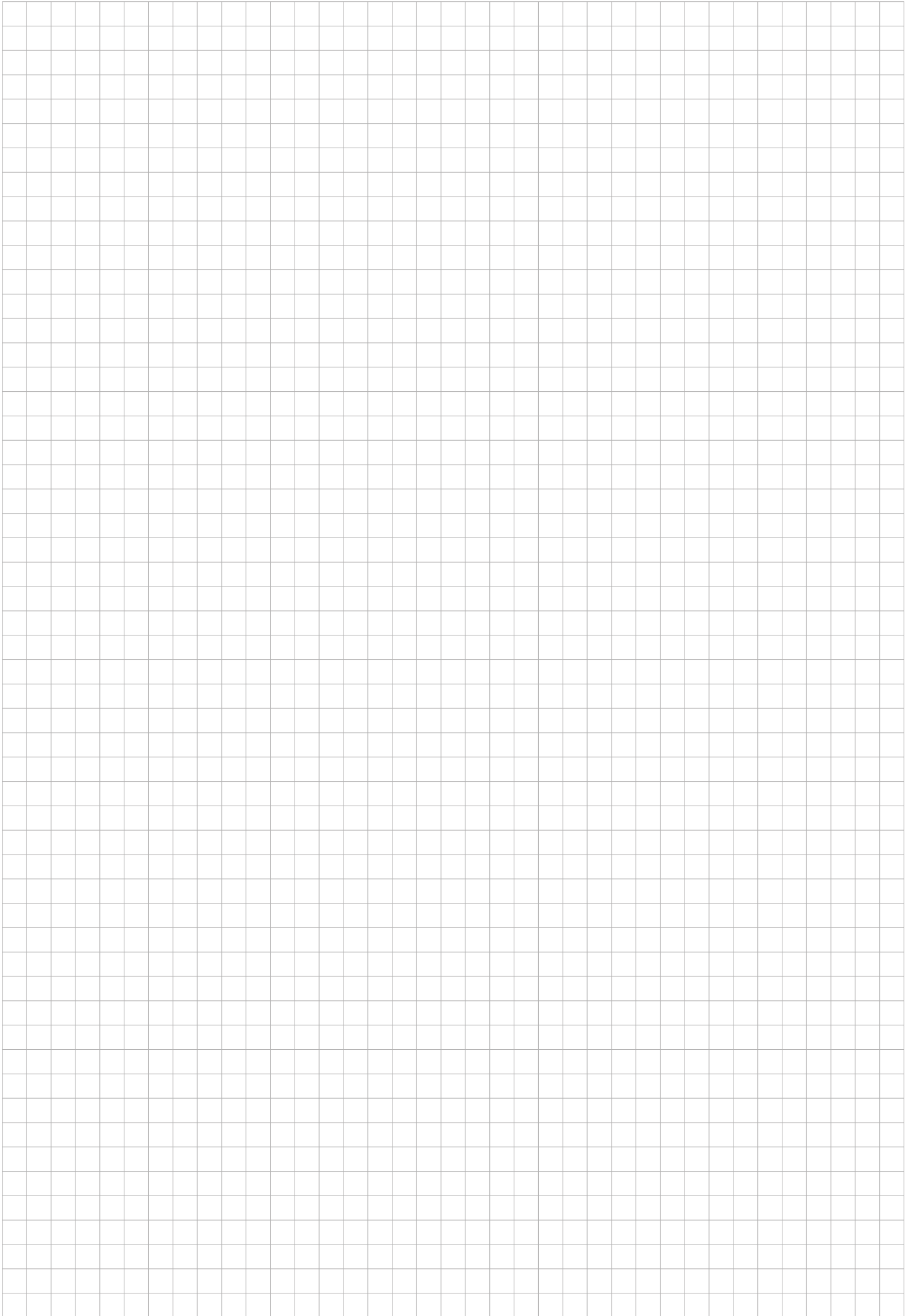

Operation · Einsatz · Utilisation  
 Uso · Эксплуатация

Working range · Arbeitsbereich · Rayon de travail  
 Zona de trabajo · Area di lavoro · Рабочая зона

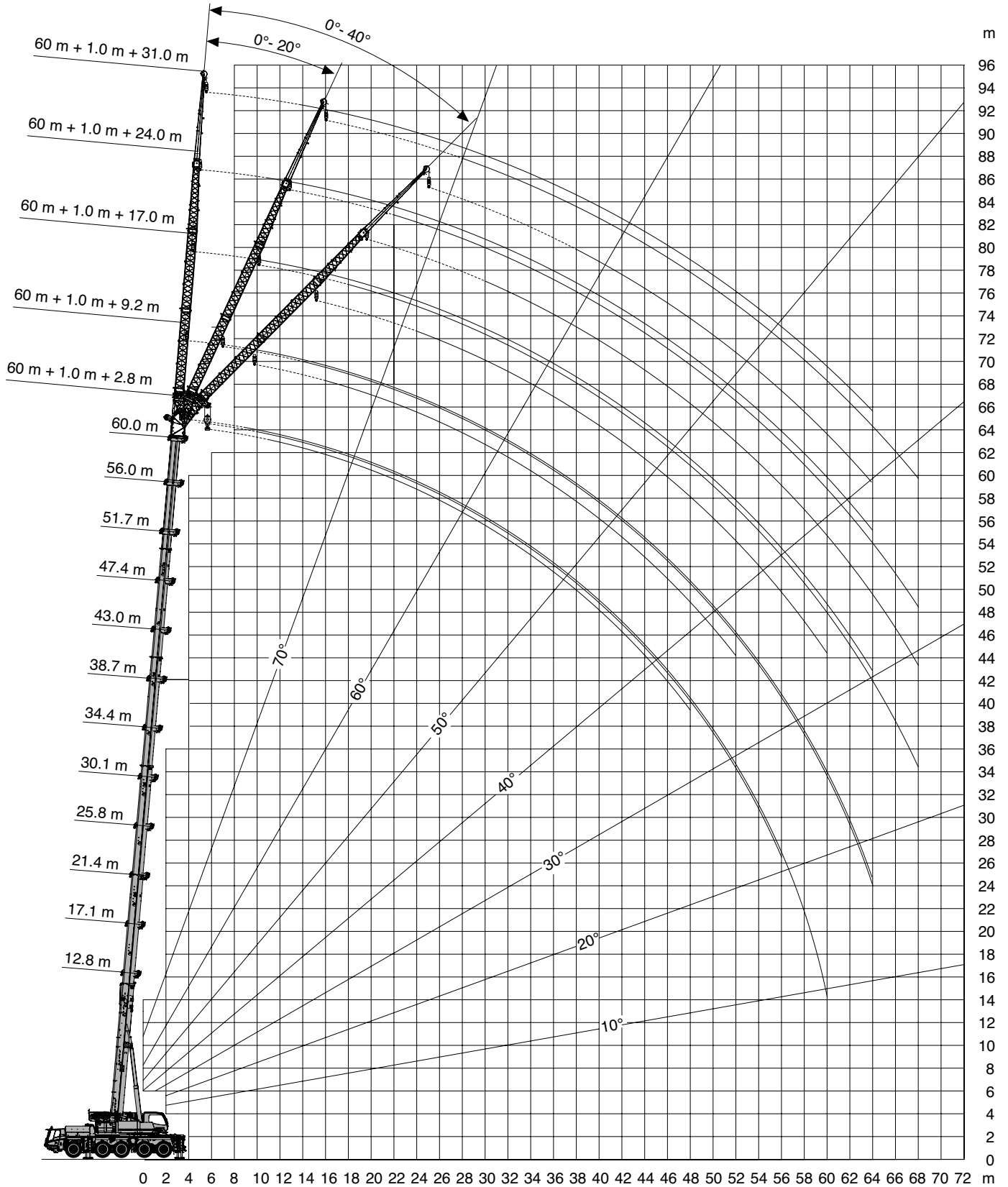
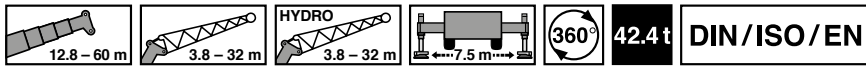

Lifting capacities · Traglasten · Charges de levage  
 Cargas · Portate · Грузоподъемность

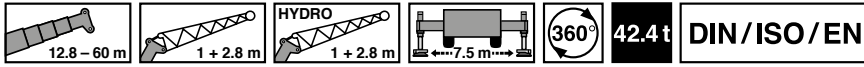

m	12.8 m + 1.0 m + 2.8 m			21.4 m + 1.0 m + 2.8 m			34.4 m + 1.0 m + 2.8 m			47.4 m + 1.0 m + 2.8 m			60.0 m + 1.0 m + 2.8 m		
	0°	20°	40°	0°	20°	40°	0°	20°	40°	0°	20°	40°	0°	20°	40°
3.0	40.0	31.8		35.0											
3.5	40.0	30.5	25.0	35.0											
4.0	39.5	29.3	24.3	35.0	33.0										
4.5	37.3	28.2	23.7	35.0	32.0	25.5	29.9								
5.0	35.4	27.2	23.1	35.0	31.1	25.0	29.9	29.9							
6.0	32.1	25.4	22.1	35.0	29.5	24.1	29.9	29.3	25.0	13.9					
7.0	29.4	24.0	21.2	35.0	28.1	23.4	28.0	27.1	24.4	13.9	12.4				
8.0	27.2	22.7	20.5	35.0	26.8	22.7	25.9	25.2	23.9	13.9	13.9	13.4			
9.0	25.3	21.6	19.9	33.5	25.7	22.0	24.2	23.5	23.0	13.9	13.7	12.9	7.8		
10.0	23.7	20.7	19.5	31.5	24.7	21.5	22.6	22.1	21.6	13.9	13.3	12.4	7.8	7.8	
11.0	22.3	20.0	19.3	29.8	23.8	21.0	21.2	20.8	20.4	13.7	12.8	12.0	7.8	7.8	7.8
12.0	21.2	19.5		28.2	23.0	20.5	20.0	19.6	19.3	13.2	12.3	11.6	7.8	7.8	7.8
14.0	19.7			25.6	21.6	19.8	17.9	17.6	17.4	12.4	11.5	10.9	7.8	7.8	7.6
16.0				23.6	20.5	19.3	16.2	16.0	15.8	11.4	10.9	10.3	7.7	7.5	7.3
18.0				19.8	19.7	19.1	14.8	14.6	14.5	10.6	10.3	9.8	7.3	7.1	6.9
20.0				16.9	17.0		13.6	13.4	13.3	9.9	9.6	9.4	6.9	6.7	6.6
22.0				15.0			12.6	12.4	12.4	9.3	9.1	8.9	6.5	6.4	6.3
24.0							11.7	11.6	11.5	8.8	8.6	8.4	6.2	6.1	6.0
26.0							10.7	10.4	10.5	8.3	8.1	8.0	5.9	5.8	5.7
28.0							10.0	10.0	9.9	7.9	7.7	7.6	5.7	5.6	5.5
30.0							8.9	9.0		7.5	7.4	7.3	5.4	5.3	5.2
32.0							7.9	8.0		7.0	7.0	7.0	5.1	5.0	5.0
34.0							7.1	7.1		6.6	6.6	6.6	4.9	4.8	4.8
36.0										5.8	5.9	5.9	4.6	4.6	4.5
38.0										5.4	5.3	5.3	4.4	4.4	4.4
40.0										5.2	5.1		4.3	4.2	4.2
44.0										4.1	4.1		3.9	3.9	3.9
48.0										3.7			3.0	3.1	3.1
52.0													2.3	2.4	
56.0													1.7	1.7	
60.0													1.2		

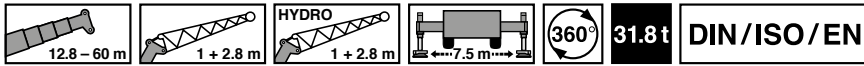

m	12.8 m + 1.0 m + 2.8 m			21.4 m + 1.0 m + 2.8 m			34.4 m + 1.0 m + 2.8 m			47.4 m + 1.0 m + 2.8 m			60.0 m + 1.0 m + 2.8 m		
	0°	20°	40°	0°	20°	40°	0°	20°	40°	0°	20°	40°	0°	20°	40°
3.0	40.0	31.8		35.0											
3.5	40.0	30.5	25.0	35.0											
4.0	39.5	29.3	24.3	35.0	33.0										
4.5	37.3	28.2	23.7	35.0	32.0	25.5	29.9								
5.0	35.4	27.2	23.1	35.0	31.1	25.0	29.9	29.9							
6.0	32.1	25.4	22.1	35.0	29.5	24.1	29.9	29.3	25.0	13.9					
7.0	29.4	24.0	21.2	35.0	28.1	23.4	28.0	27.1	24.4	13.9	12.4				
8.0	27.2	22.7	20.5	35.0	26.8	22.7	25.9	25.2	23.9	13.9	13.9	13.4			
9.0	25.3	21.6	19.9	33.5	25.7	22.0	24.2	23.5	23.0	13.9	13.7	12.9	7.8		
10.0	23.7	20.7	19.5	31.5	24.7	21.5	22.6	22.1	21.6	13.9	13.3	12.4	7.8	7.8	
11.0	22.3	20.0	19.3	29.8	23.8	21.0	21.2	20.8	20.4	13.7	12.8	12.0	7.8	7.8	7.8
12.0	21.2	19.5		28.2	23.0	20.5	20.0	19.6	19.3	13.2	12.3	11.6	7.8	7.8	7.8
14.0	19.7			24.2	21.6	19.8	17.9	17.6	17.4	12.4	11.5	10.9	7.8	7.8	7.6
16.0				19.6	19.8	19.3	16.2	16.0	15.8	11.4	10.9	10.3	7.7	7.5	7.3
18.0				16.9	17.0	17.1	14.8	14.6	14.5	10.6	10.3	9.8	7.3	7.1	6.9
20.0				14.3	14.4		12.9	13.1	13.3	9.9	9.6	9.4	6.9	6.7	6.6
22.0				12.3			11.6	11.1	11.2	9.3	9.1	8.9	6.5	6.4	6.3
24.0							10.4	10.5	10.4	8.8	8.6	8.4	6.2	6.1	6.0
26.0							9.0	9.1	9.2	8.3	8.1	8.0	5.9	5.8	5.7
28.0							8.0	8.1	8.2	7.3	7.4	7.5	5.7	5.6	5.5
30.0							7.0	7.0		6.5	6.4	6.5	5.4	5.3	5.2
32.0							6.1	6.1		6.1	6.1	6.0	5.1	5.0	5.0
34.0							5.4	5.4		5.3	5.4	5.4	4.9	4.8	4.8
36.0										4.9	4.8	4.8	4.4	4.5	4.5
38.0										4.6	4.6	4.6	3.8	3.9	4.0
40.0										4.1	4.1		3.3	3.4	3.4
44.0										3.2	3.2		2.4	2.5	2.5
48.0										2.4			1.7	1.7	1.7
52.0													1.1	1.1	

Operation · Einsatz · Utilisation  
 Uso · Эксплуатация

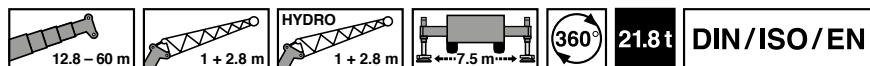

m	12.8 m + 1.0 m + 2.8 m			21.4 m + 1.0 m + 2.8 m			34.4 m + 1.0 m + 2.8 m			47.4 m + 1.0 m + 2.8 m			60.0 m + 1.0 m + 2.8 m		
	0°	20°	40°	0°	20°	40°	0°	20°	40°	0°	20°	40°	0°	20°	40°
3.0	40.0	31.8		35.0											
3.5	40.0	30.5	25.0	35.0											
4.0	39.5	29.3	24.3	35.0	33.0										
4.5	37.3	28.2	23.7	35.0	32.0	25.5	29.9								
5.0	35.4	27.2	23.1	35.0	31.1	25.0	29.9	29.9							
6.0	32.1	25.4	22.1	35.0	29.5	24.1	29.9	29.3	25.0	13.9					
7.0	29.4	24.0	21.2	35.0	28.1	23.4	28.0	27.1	24.4	13.9	12.4				
8.0	27.2	22.7	20.5	35.0	26.8	22.7	25.9	25.2	23.9	13.9	13.9	13.4			
9.0	25.3	21.6	19.9	33.5	25.7	22.0	24.2	23.5	23.0	13.9	13.7	12.9	7.8		
10.0	23.7	20.7	19.5	31.5	24.7	21.5	22.6	22.1	21.6	13.9	13.3	12.4	7.8	7.8	
11.0	22.3	20.0	19.3	29.0	23.8	21.0	21.2	20.8	20.4	13.7	12.8	12.0	7.8	7.8	7.8
12.0	21.2	19.5		25.2	23.0	20.5	20.0	19.6	19.3	13.2	12.3	11.6	7.8	7.8	7.8
14.0	19.7			20.3	20.5	19.8	17.9	17.6	17.4	12.4	11.5	10.9	7.8	7.8	7.6
16.0				16.4	16.6	16.7	14.9	15.2	15.5	11.4	10.9	10.3	7.7	7.5	7.3
18.0				13.5	13.7	13.7	12.8	12.4	12.5	10.6	10.3	9.8	7.3	7.1	6.9
20.0				12.0	11.9		11.1	11.3	11.1	9.9	9.6	9.4	6.9	6.7	6.6
22.0				10.2			9.4	9.6	9.7	8.7	8.9	8.9	6.5	6.4	6.3
24.0							7.9	8.0	8.2	7.7	7.5	7.5	6.2	6.1	6.0
26.0							6.7	6.8	6.9	6.7	6.8	6.9	5.9	5.8	5.7
28.0							6.1	6.1	6.1	6.0	5.9	5.9	5.5	5.6	5.5
30.0							5.8	5.8		5.4	5.5	5.6	4.6	4.7	4.8
32.0							5.3	5.4		4.6	4.7	4.8	3.9	4.0	4.1
34.0							4.7	4.7		4.0	4.1	4.1	3.2	3.3	3.4
36.0										3.4	3.5	3.5	2.7	2.8	2.8
38.0										2.9	3.0	3.0	2.2	2.3	2.3
40.0										2.5	2.5		1.7	1.8	1.9
44.0										1.7	1.8		1.0	1.1	1.1
48.0										1.2					

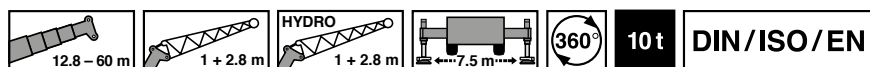

m	12.8 m + 1.0 m + 2.8 m			21.4 m + 1.0 m + 2.8 m			34.4 m + 1.0 m + 2.8 m			47.4 m + 1.0 m + 2.8 m			60.0 m + 1.0 m + 2.8 m		
	0°	20°	40°	0°	20°	40°	0°	20°	40°	0°	20°	40°	0°	20°	40°
3.0	40.0	31.8		35.0											
3.5	40.0	30.5	25.0	35.0											
4.0	39.5	29.3	24.3	35.0	33.0										
4.5	37.3	28.2	23.7	35.0	32.0	25.5	29.9								
5.0	35.4	27.2	23.1	35.0	31.1	25.0	29.9	29.9							
6.0	32.1	25.4	22.1	35.0	29.5	24.1	29.9	29.3	25.0	13.9					
7.0	29.4	24.0	21.2	35.0	28.1	23.4	28.0	27.1	24.4	13.9	12.4				
8.0	27.2	22.7	20.5	35.0	26.8	22.7	25.9	25.2	23.9	13.9	13.9	13.4			
9.0	25.3	21.6	19.9	29.7	25.7	22.0	24.2	23.5	23.0	13.9	13.7	12.9	7.8		
10.0	23.7	20.7	19.5	26.3	24.7	21.5	20.7	21.4	21.6	13.9	13.3	12.4	7.8	7.8	
11.0	22.1	20.0	19.3	22.4	22.8	21.0	18.0	18.6	19.1	13.7	12.8	12.0	7.8	7.8	7.8
12.0	19.1	19.3		19.3	19.7	19.9	15.8	16.2	16.7	13.2	12.3	11.6	7.8	7.8	7.8
14.0	14.4			14.9	15.0	15.2	13.9	13.5	13.0	11.6	11.5	10.9	7.8	7.8	7.6
16.0				12.2	12.4	12.5	11.3	11.6	11.9	10.2	9.9	9.9	7.7	7.5	7.3
18.0				9.8	9.9	10.0	9.0	9.2	9.5	8.4	8.6	8.9	7.3	7.1	6.9
20.0				8.0	8.1		8.0	8.1	8.1	7.7	7.6	7.5	6.2	6.4	6.6
22.0				6.6			7.1	7.3	7.2	6.4	6.6	6.7	5.1	5.3	5.4
24.0							6.0	6.1	6.1	5.2	5.4	5.5	4.2	4.3	4.5
26.0							5.0	5.1	5.2	4.3	4.4	4.5	3.4	3.6	3.7
28.0							4.2	4.3	4.3	3.5	3.6	3.7	2.7	2.9	3.0
30.0							3.6	3.6		2.9	3.0	3.0	2.1	2.2	2.3
32.0							3.0	3.0		2.3	2.4	2.4	1.5	1.6	1.7
34.0							2.5	2.5		1.8	1.9	1.9			
36.0										1.4	1.4	1.5			
38.0										1.0	1.1	1.1			

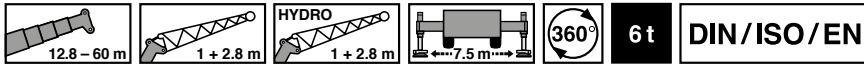

 m	12.8 m + 1.0 m + 2.8 m			21.4 m + 1.0 m + 2.8 m			34.4 m + 1.0 m + 2.8 m			47.4 m + 1.0 m + 2.8 m			60.0 m + 1.0 m + 2.8 m		
	0°	20°	40°	0°	20°	40°	0°	20°	40°	0°	20°	40°	0°	20°	40°
3.0	40.0	31.8		35.0											
3.5	40.0	30.5	25.0	35.0											
4.0	39.5	29.3	24.3	35.0	33.0										
4.5	37.3	28.2	23.7	35.0	32.0	25.5	29.9								
5.0	35.4	27.2	23.1	35.0	31.1	25.0	29.9	29.9							
6.0	32.1	25.4	22.1	35.0	29.5	24.1	29.9	29.3	25.0	13.9					
7.0	29.4	24.0	21.2	35.0	28.1	23.4	28.0	27.1	24.4	13.9	12.4				
8.0	27.2	22.7	20.5	31.0	26.8	22.7	24.7	25.2	23.9	13.9	13.9	13.4			
9.0	25.3	21.6	19.9	26.9	25.7	22.0	20.7	21.5	22.2	13.9	13.7	12.9	7.8		
10.0	23.2	20.7	19.5	22.9	23.5	21.5	17.7	18.3	18.9	13.9	13.3	12.4	7.8	7.8	
11.0	19.6	19.9	19.3	19.8	20.3	20.6	16.5	15.8	16.3	13.7	12.8	12.0	7.8	7.8	7.8
12.0	16.6	16.9		16.9	17.4	17.6	15.0	14.5	14.2	12.4	12.3	11.6	7.8	7.8	7.8
14.0	12.2			13.3	13.7	13.5	11.8	12.2	12.5	10.5	10.7	10.4	7.8	7.8	7.6
16.0				10.3	10.6	10.7	9.9	9.7	10.0	9.1	8.8	9.0	7.5	7.5	7.3
18.0				8.3	8.4	8.4	8.6	8.4	8.5	7.6	7.8	8.0	6.0	6.3	6.5
20.0				6.6	6.7		7.2	7.3	7.4	6.3	6.5	6.6	4.8	5.1	5.2
22.0				5.4			5.9	6.0	6.1	5.1	5.3	5.5	3.9	4.1	4.2
24.0							4.9	5.0	5.0	4.1	4.3	4.4	3.0	3.2	3.4
26.0							4.0	4.1	4.1	3.3	3.4	3.5	2.3	2.5	2.6
28.0							3.3	3.4	3.4	2.6	2.7	2.8		1.9	2.0
30.0							2.7	2.8		2.0	2.1	2.2			
32.0							2.2	2.2		1.5	1.6	1.6			
34.0							1.8	1.8		1.1	1.1	1.2			

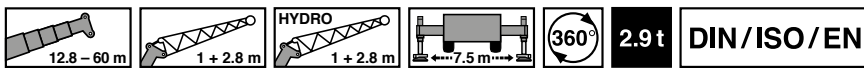

 m	12.8 m + 1.0 m + 2.8 m			21.4 m + 1.0 m + 2.8 m			34.4 m + 1.0 m + 2.8 m			47.4 m + 1.0 m + 2.8 m			60.0 m + 1.0 m + 2.8 m		
	0°	20°	40°	0°	20°	40°	0°	20°	40°	0°	20°	40°	0°	20°	40°
3.0	40.0	31.8		35.0											
3.5	40.0	30.5	25.0	35.0											
4.0	39.5	29.3	24.3	35.0	33.0										
4.5	37.3	28.2	23.7	35.0	32.0	25.5	29.9								
5.0	35.4	27.2	23.1	35.0	31.1	25.0	29.9	29.9							
6.0	32.1	25.4	22.1	35.0	29.5	24.1	29.9	29.3	25.0	13.9					
7.0	29.4	24.0	21.2	33.6	28.1	23.4	26.1	27.1	24.4	13.9	12.4				
8.0	27.2	22.7	20.5	28.3	26.8	22.7	21.4	22.3	23.1	13.9	13.9	13.4			
9.0	25.1	21.6	19.9	23.6	24.3	22.0	18.1	18.7	19.3	13.9	13.7	12.9	7.8		
10.0	20.7	20.7	19.5	20.0	20.6	21.1	16.9	15.8	16.4	13.9	13.3	12.4	7.8	7.8	
11.0	17.1	17.5	17.7	17.2	17.7	18.1	14.8	15.0	14.3	12.4	12.5	12.0	7.8	7.8	7.8
12.0	14.3	14.6		15.5	15.2	15.4	12.9	13.3	13.6	11.4	11.6	11.3	7.8	7.8	7.8
14.0	10.4			11.5	11.8	12.0	10.9	10.7	10.7	9.7	9.5	9.5	7.7	7.8	7.6
16.0				8.9	9.1	9.1	9.4	9.1	9.3	7.8	8.0	8.2	6.1	6.4	6.6
18.0				6.9	7.1	7.1	7.5	7.7	7.8	6.3	6.5	6.7	4.8	5.0	5.3
20.0				5.5	5.5		6.0	6.2	6.3	5.1	5.3	5.5	3.7	3.9	4.1
22.0				4.3			4.9	5.0	5.1	4.1	4.3	4.4	2.8	3.0	3.2
24.0							3.9	4.0	4.1	3.2	3.4	3.5	2.1	2.3	2.4
26.0							3.2	3.3	3.3	2.4	2.6	2.7			
28.0							2.5	2.6	2.6	1.8	1.9	2.0			
30.0							2.0	2.0		1.3	1.4	1.5			
32.0							1.5	1.6			0.9	1.0			
34.0							1.1	1.1							

Operation · Einsatz · Utilisation  
 Uso · Эксплуатация

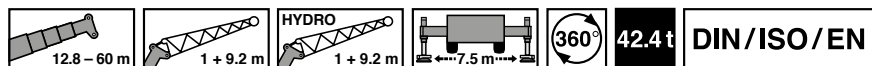

m	12.8 m + 1.0 m + 9.2 m			21.4 m + 1.0 m + 9.2 m			34.4 m + 1.0 m + 9.2 m			47.4 m + 1.0 m + 9.2 m			60.0 m + 1.0 m + 9.2 m		
	0°	20°	40°	0°	20°	40°	0°	20°	40°	0°	20°	40°	0°	20°	40°
3.0	15.0			15.0											
3.5	15.0			15.0											
4.0	15.0			15.0			15.0								
4.5	15.0			15.0			15.0								
5.0	15.0	15.0		15.0			15.0								
6.0	15.0	13.8		15.0	15.0		15.0			8.4					
7.0	15.0	12.7		15.0	14.4		15.0			7.5					
8.0	15.0	11.8	9.3	15.0	13.6		15.0	14.6		8.4					
9.0	14.8	11.0	8.9	15.0	12.8	9.5	15.0	14.0		8.4			5.7		
10.0	13.5	10.3	8.5	15.0	12.1	9.2	15.0	13.4	9.6	8.4	8.4		5.7		
11.0	12.4	9.7	8.1	15.0	11.5	8.9	15.0	12.9	9.4	8.4	8.4		5.7		
12.0	11.4	9.2	7.8	15.0	10.9	8.6	15.0	12.4	9.1	8.4	8.4		5.7		
14.0	9.8	8.3	7.3	13.9	10.0	8.1	15.0	11.5	8.6	8.4	8.4	7.8	5.7	5.7	
16.0	8.5	7.6	6.9	12.2	9.2	7.7	15.0	10.7	8.3	8.4	8.2	7.4	5.7	5.7	5.4
18.0	7.5	7.0		10.8	8.6	7.3	14.1	10.1	8.0	8.4	7.8	7.1	5.7	5.5	5.2
20.0	6.7	6.7		9.6	8.0	7.0	12.9	9.5	7.7	8.4	7.4	6.8	5.7	5.3	4.9
22.0				8.7	7.5	6.8	11.9	9.0	7.4	8.1	7.1	6.5	5.5	5.0	4.7
24.0				7.9	7.2	6.7	11.0	8.6	7.2	7.7	6.8	6.3	5.3	4.8	4.5
26.0				7.3	6.9		10.3	8.2	7.0	7.4	6.6	6.0	5.0	4.6	4.4
28.0				6.7	6.7		9.5	7.8	6.9	7.1	6.3	5.8	4.8	4.4	4.2
30.0							8.5	7.5	6.7	6.8	6.1	5.6	4.6	4.3	4.1
32.0							7.5	7.3	6.6	6.5	5.9	5.5	4.4	4.1	3.9
34.0							6.8	7.0	6.6	6.1	5.7	5.3	4.2	4.0	3.8
36.0							6.6	6.2		5.9	5.6	5.2	4.0	3.8	3.7
38.0							6.1	5.9		5.5	5.4	5.1	3.9	3.7	3.6
40.0							5.6	5.7		4.9	5.2	5.0	3.8	3.6	3.5
44.0										4.3	4.1	4.2	3.5	3.3	3.3
48.0										3.5	3.7		3.2	3.2	3.1
52.0										3.0	3.0		2.5	2.7	2.8
56.0													1.9	2.1	
60.0													1.4	1.5	
64.0													0.9	1.0	

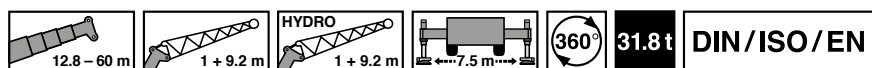

m	12.8 m + 1.0 m + 9.2 m			21.4 m + 1.0 m + 9.2 m			34.4 m + 1.0 m + 9.2 m			47.4 m + 1.0 m + 9.2 m			60.0 m + 1.0 m + 9.2 m		
	0°	20°	40°	0°	20°	40°	0°	20°	40°	0°	20°	40°	0°	20°	40°
3.0	15.0			15.0											
3.5	15.0			15.0											
4.0	15.0			15.0			15.0								
4.5	15.0			15.0			15.0								
5.0	15.0	15.0		15.0			15.0								
6.0	15.0	13.8		15.0	15.0		15.0			8.4					
7.0	15.0	12.7		15.0	14.4		15.0			7.5					
8.0	15.0	11.8	9.3	15.0	13.6		15.0	14.6		8.4					
9.0	14.8	11.0	8.9	15.0	12.8	9.5	15.0	14.0		8.4			5.7		
10.0	13.5	10.3	8.5	15.0	12.1	9.2	15.0	13.4	9.6	8.4	8.4		5.7		
11.0	12.4	9.7	8.1	15.0	11.5	8.9	15.0	12.9	9.4	8.4	8.4		5.7		
12.0	11.4	9.2	7.8	15.0	10.9	8.6	15.0	12.4	9.1	8.4	8.4		5.7		
14.0	9.8	8.3	7.3	13.9	10.0	8.1	15.0	11.5	8.6	8.4	8.4	7.8	5.7	5.7	
16.0	8.5	7.6	6.9	12.2	9.2	7.7	15.0	10.7	8.3	8.4	8.2	7.4	5.7	5.7	5.4
18.0	7.5	7.0		10.8	8.6	7.3	14.1	10.1	8.0	8.4	7.8	7.1	5.7	5.5	5.2
20.0	6.7	6.7		9.6	8.0	7.0	12.9	9.5	7.7	8.4	7.4	6.8	5.7	5.3	4.9
22.0				8.7	7.5	6.8	11.5	9.0	7.4	8.1	7.1	6.5	5.5	5.0	4.7
24.0				7.9	7.2	6.7	9.9	8.6	7.2	7.7	6.8	6.3	5.3	4.8	4.5
26.0				7.3	6.9		8.6	8.2	7.0	7.4	6.6	6.0	5.0	4.6	4.4
28.0				6.7	6.7		7.7	7.8	6.9	7.1	6.3	5.8	4.8	4.4	4.2
30.0							7.3	6.8	6.7	6.6	6.1	5.6	4.6	4.3	4.1
32.0							6.5	6.3	6.1	5.8	5.9	5.5	4.4	4.1	3.9
34.0							5.8	6.1	5.8	5.3	5.4	5.3	4.2	4.0	3.8
36.0							5.1	5.3		4.9	4.9	5.0	4.0	3.8	3.7
38.0							4.5	4.7		4.3	4.6	4.6	3.9	3.7	3.6
40.0							4.0	4.1		4.1	4.1	4.2	3.5	3.6	3.5
44.0										3.4	3.6	3.6	2.6	2.9	3.1
48.0										2.7	2.8		1.9	2.1	2.3
52.0										2.0	2.1		1.2	1.5	1.6
56.0													0.9		

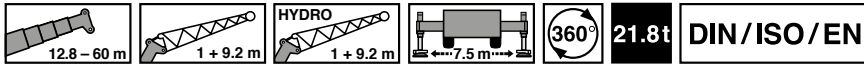

m	12.8 m + 1.0 m + 9.2 m			21.4 m + 1.0 m + 9.2 m			34.4 m + 1.0 m + 9.2 m			47.4 m + 1.0 m + 9.2 m			60.0 m + 1.0 m + 9.2 m		
	0°	20°	40°	0°	20°	40°	0°	20°	40°	0°	20°	40°	0°	20°	40°
3.0	15.0			15.0											
3.5	15.0			15.0											
4.0	15.0			15.0			15.0								
4.5	15.0			15.0			15.0								
5.0	15.0	15.0		15.0			15.0								
6.0	15.0	13.8		15.0	15.0		15.0			8.4					
7.0	15.0	12.7		15.0	14.4		15.0			7.5					
8.0	15.0	11.8	9.3	15.0	13.6		15.0	14.6		8.4					
9.0	14.8	11.0	8.9	15.0	12.8	9.5	15.0	14.0		8.4			5.7		
10.0	13.5	10.3	8.5	15.0	12.1	9.2	15.0	13.4	9.6	8.4	8.4		5.7		
11.0	12.4	9.7	8.1	15.0	11.5	8.9	15.0	12.9	9.4	8.4	8.4		5.7		
12.0	11.4	9.2	7.8	15.0	10.9	8.6	15.0	12.4	9.1	8.4	8.4		5.7		
14.0	9.8	8.3	7.3	13.9	10.0	8.1	15.0	11.5	8.6	8.4	8.4	7.8	5.7	5.7	
16.0	8.5	7.6	6.9	12.2	9.2	7.7	15.0	10.7	8.3	8.4	8.2	7.4	5.7	5.7	5.4
18.0	7.5	7.0		10.8	8.6	7.3	12.6	10.1	8.0	8.4	7.8	7.1	5.7	5.5	5.2
20.0	6.7	6.7		9.6	8.0	7.0	10.5	9.5	7.7	8.4	7.4	6.8	5.7	5.3	4.9
22.0				8.7	7.5	6.8	9.0	9.0	7.4	8.1	7.1	6.5	5.5	5.0	4.7
24.0				7.9	7.2	6.7	8.4	7.9	7.2	7.5	6.8	6.3	5.3	4.8	4.5
26.0				7.2	6.9		7.1	7.1	7.0	6.7	6.6	6.0	5.0	4.6	4.4
28.0				6.7	6.7		6.1	6.6	6.3	6.0	5.9	5.8	4.8	4.4	4.2
30.0							5.3	5.7	5.9	5.2	5.6	5.5	4.6	4.3	4.1
32.0							5.0	4.9	5.1	4.9	4.8	5.1	4.1	4.1	3.9
34.0							4.5	4.6	4.6	4.2	4.5	4.4	3.4	3.9	3.8
36.0							4.3	4.2		3.7	4.0	4.2	2.9	3.3	3.6
38.0							3.9	4.0		3.2	3.5	3.7	2.4	2.7	3.0
40.0							3.5	3.6		2.7	3.0	3.1	1.9	2.3	2.5
44.0										2.0	2.2	2.3	1.2	1.5	1.7
48.0										1.4	1.5				1.0
52.0										0.9	1.0				

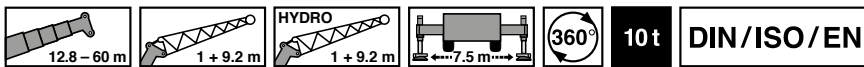

m	12.8 m + 1.0 m + 9.2 m			21.4 m + 1.0 m + 9.2 m			34.4 m + 1.0 m + 9.2 m			47.4 m + 1.0 m + 9.2 m			60.0 m + 1.0 m + 9.2 m		
	0°	20°	40°	0°	20°	40°	0°	20°	40°	0°	20°	40°	0°	20°	40°
3.0	15.0			15.0											
3.5	15.0			15.0											
4.0	15.0			15.0			15.0								
4.5	15.0			15.0			15.0								
5.0	15.0	15.0		15.0			15.0								
6.0	15.0	13.8		15.0	15.0		15.0			8.4					
7.0	15.0	12.7		15.0	14.4		15.0			7.5					
8.0	15.0	11.8	9.3	15.0	13.6		15.0	14.6		8.4					
9.0	14.8	11.0	8.9	15.0	12.8	9.5	15.0	14.0		8.4			5.7		
10.0	13.5	10.3	8.5	15.0	12.1	9.2	15.0	13.4	9.6	8.4	8.4		5.7		
11.0	12.4	9.7	8.1	15.0	11.5	8.9	15.0	12.9	9.4	8.4	8.4		5.7		
12.0	11.4	9.2	7.8	15.0	10.9	8.6	15.0	12.4	9.1	8.4	8.4		5.7		
14.0	9.8	8.3	7.3	13.9	10.0	8.1	12.2	11.5	8.6	8.4	8.4	7.8	5.7	5.7	
16.0	8.5	7.6	6.9	12.1	9.2	7.7	11.0	10.7	8.3	8.4	8.2	7.4	5.7	5.7	5.4
18.0	7.5	7.0		10.1	8.6	7.3	9.3	8.9	8.0	7.5	7.8	7.1	5.7	5.5	5.2
20.0	6.7	6.7		8.8	8.0	7.0	7.7	8.2	7.7	6.9	7.2	6.8	5.7	5.3	4.9
22.0				7.3	7.4	6.8	6.9	6.9	7.0	6.4	6.5	6.5	5.0	5.0	4.7
24.0				6.2	6.5	6.7	6.1	6.2	6.2	5.5	5.6	6.0	4.1	4.8	4.5
26.0				5.3	5.5		5.3	5.5	5.6	4.6	5.1	5.1	3.4	4.0	4.4
28.0				4.5	4.7		4.5	4.8	5.1	3.8	4.3	4.6	2.7	3.3	3.7
30.0							3.8	4.1	4.4	3.1	3.5	3.9	2.1	2.6	3.1
32.0							3.3	3.5	3.8	2.5	2.9	3.2	1.6	2.1	2.5
34.0							2.8	3.0	3.2	2.1	2.4	2.7		1.6	2.0
36.0							2.3	2.5		1.6	1.9	2.2			1.5
38.0							2.0	2.1		1.2	1.5	1.7			
40.0							1.6	1.7		0.9	1.2	1.3			

Operation · Einsatz · Utilisation  
 Uso · Эксплуатация

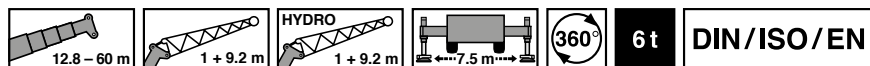

m	12.8 m + 1.0 m + 9.2 m			21.4 m + 1.0 m + 9.2 m			34.4 m + 1.0 m + 9.2 m			47.4 m + 1.0 m + 9.2 m			60.0 m + 1.0 m + 9.2 m		
	0°	20°	40°	0°	20°	40°	0°	20°	40°	0°	20°	40°	0°	20°	40°
3.0	15.0			15.0											
3.5	15.0			15.0											
4.0	15.0			15.0			15.0								
4.5	15.0			15.0			15.0								
5.0	15.0	15.0		15.0			15.0								
6.0	15.0	13.8		15.0	15.0		15.0			8.4					
7.0	15.0	12.7		15.0	14.4		15.0			7.5					
8.0	15.0	11.8	9.3	15.0	13.6		15.0	14.6		8.4					
9.0	14.8	11.0	8.9	15.0	12.8	9.5	15.0	14.0		8.4			5.7		
10.0	13.5	10.3	8.5	15.0	12.1	9.2	15.0	13.4	9.6	8.4	8.4		5.7		
11.0	12.4	9.7	8.1	15.0	11.5	8.9	14.9	12.9	9.4	8.4	8.4		5.7		
12.0	11.4	9.2	7.8	15.0	10.9	8.6	13.3	12.4	9.1	8.4	8.4		5.7		
14.0	9.8	8.3	7.3	13.7	10.0	8.1	11.6	11.5	8.6	8.4	8.4	7.8	5.7	5.7	
16.0	8.5	7.6	6.9	10.7	9.2	7.7	9.4	9.2	8.3	7.5	8.2	7.4	5.7	5.7	5.4
18.0	7.5	7.0		9.0	8.6	7.3	8.4	8.6	8.0	6.8	7.5	7.1	5.7	5.5	5.2
20.0	6.7	6.7		7.4	7.9	7.0	7.1	7.4	7.3	6.2	6.3	6.6	4.7	5.3	4.9
22.0				6.1	6.5	6.8	6.1	6.2	6.7	5.2	5.8	5.8	3.8	4.5	4.7
24.0				5.1	5.4	5.6	5.1	5.6	5.7	4.3	4.9	5.3	3.0	3.7	4.2
26.0				4.3	4.5		4.3	4.7	5.1	3.5	4.1	4.5	2.3	2.9	3.4
28.0				3.6	3.7		3.6	3.9	4.3	2.8	3.3	3.7	1.8	2.3	2.8
30.0							3.0	3.3	3.6	2.3	2.7	3.0		1.8	2.2
32.0							2.5	2.7	3.0	1.7	2.1	2.4			1.6
34.0							2.0	2.2	2.5	1.3	1.7	1.9			
36.0							1.6	1.8		0.9	1.2	1.5			
38.0							1.3	1.4			0.9	1.1			
40.0							1.0	1.1							

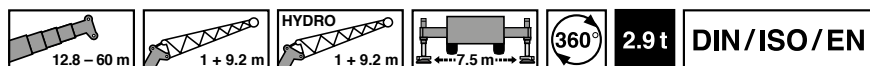

m	12.8 m + 1.0 m + 9.2 m			21.4 m + 1.0 m + 9.2 m			34.4 m + 1.0 m + 9.2 m			47.4 m + 1.0 m + 9.2 m			60.0 m + 1.0 m + 9.2 m		
	0°	20°	40°	0°	20°	40°	0°	20°	40°	0°	20°	40°	0°	20°	40°
3.0	15.0			15.0											
3.5	15.0			15.0											
4.0	15.0			15.0			15.0								
4.5	15.0			15.0			15.0								
5.0	15.0	15.0		15.0			15.0								
6.0	15.0	13.8		15.0	15.0		15.0			8.4					
7.0	15.0	12.7		15.0	14.4		15.0			7.5					
8.0	15.0	11.8	9.3	15.0	13.6		15.0	14.6		8.4					
9.0	14.8	11.0	8.9	15.0	12.8	9.5	15.0	14.0		8.4			5.7		
10.0	13.5	10.3	8.5	15.0	12.1	9.2	14.7	13.4	9.6	8.4	8.4		5.7		
11.0	12.4	9.7	8.1	15.0	11.5	8.9	13.4	12.9	9.4	8.4	8.4		5.7		
12.0	11.4	9.2	7.8	15.0	10.9	8.6	12.6	12.4	9.1	8.4	8.4		5.7		
14.0	9.8	8.3	7.3	11.8	10.0	8.1	10.3	9.9	8.6	7.9	8.4	7.8	5.7	5.7	
16.0	8.5	7.6	6.9	9.7	9.2	7.7	8.7	8.9	8.3	6.9	7.5	7.4	5.7	5.7	5.4
18.0	7.5	7.0		7.7	8.3	7.3	7.7	7.9	7.7	6.2	6.5	6.9	4.6	5.5	5.2
20.0	6.1	6.3		6.3	6.7	7.0	6.3	6.6	7.0	5.1	5.8	5.9	3.6	4.4	4.9
22.0				5.1	5.5	5.8	5.1	5.6	6.0	4.1	4.8	5.3	2.8	3.5	4.1
24.0				4.2	4.5	4.7	4.2	4.6	5.1	3.4	3.9	4.4	2.1	2.7	3.3
26.0				3.4	3.7		3.4	3.8	4.2	2.7	3.2	3.6		2.1	2.6
28.0				2.8	3.0		2.8	3.1	3.5	2.1	2.6	2.9			2.0
30.0							2.2	2.5	2.9	1.5	2.0	2.3			
32.0							1.8	2.0	2.3	1.1	1.5	1.8			
34.0							1.4	1.6	1.8		1.0	1.3			
36.0							1.1	1.2							
38.0								0.9							



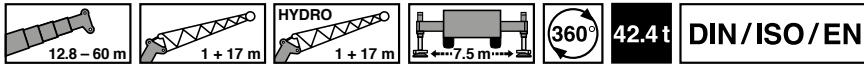

m	12.8 m + 1.0 m + 17.0 m			21.4 m + 1.0 m + 17.0 m			34.4 m + 1.0 m + 17.0 m			47.4 m + 1.0 m + 17.0 m			60.0 m + 1.0 m + 17.0 m		
	0°	20°	40°	0°	20°	40°	0°	20°	40°	0°	20°	40°	0°	20°	40°
3.0	7.8														
3.5	7.8														
4.0	7.8			7.4											
4.5	7.8			7.4											
5.0	7.8			7.4											
6.0	7.6			7.4			6.4								
7.0	7.2			7.4			6.4			4.7					
8.0	6.7			7.3			6.4			4.7					
9.0	6.3	5.1		7.0			6.4			4.7					
10.0	6.0	4.8		6.6	5.0		6.4			4.7			3.6		
11.0	5.6	4.6		6.3	4.8		6.4	4.8		4.7			3.6		
12.0	5.3	4.4		6.1	4.6		6.4	4.7		4.7			3.6		
14.0	4.8	4.0	3.5	5.5	4.3		6.0	4.4		4.7	4.2		3.6		
16.0	4.3	3.7	3.3	5.1	4.0	3.4	5.7	4.2	3.4	4.7	4.1		3.6		
18.0	4.0	3.4	3.1	4.7	3.8	3.2	5.3	4.0	3.3	4.7	3.9		3.6	3.6	
20.0	3.7	3.2	3.0	4.4	3.5	3.1	5.0	3.8	3.2	4.7	3.7	3.1	3.6	3.5	
22.0	3.4	3.1	2.9	4.1	3.4	3.0	4.7	3.6	3.1	4.7	3.6	3.0	3.6	3.4	
24.0	3.2	2.9	2.8	3.8	3.2	2.9	4.4	3.5	3.0	4.5	3.5	2.9	3.6	3.3	2.8
26.0	3.0	2.8	2.8	3.6	3.1	2.8	4.2	3.3	2.9	4.3	3.3	2.9	3.6	3.2	2.8
28.0	2.9	2.8		3.4	3.0	2.8	4.0	3.2	2.8	4.2	3.2	2.8	3.6	3.1	2.7
30.0				3.2	2.9	2.7	3.8	3.1	2.8	4.0	3.1	2.7	3.6	3.0	2.7
32.0				3.1	2.8	2.7	3.6	3.0	2.7	3.8	3.0	2.7	3.5	2.9	2.6
34.0				3.0	2.7		3.5	2.9	2.7	3.7	3.0	2.6	3.4	2.9	2.5
36.0				2.9	2.7		3.3	2.8	2.6	3.6	2.9	2.6	3.2	2.8	2.5
38.0							3.2	2.8	2.6	3.4	2.8	2.5	3.1	2.7	2.5
40.0							3.1	2.7	2.6	3.3	2.7	2.5	3.0	2.7	2.4
44.0							2.9	2.6	2.5	3.1	2.6	2.4	2.8	2.6	2.3
48.0							2.8	2.6		3.0	2.5	2.4	2.6	2.4	2.3
52.0										2.8	2.5	2.4	2.5	2.3	2.2
56.0										2.5	2.4		2.1	2.2	2.1
60.0										2.1	2.2		1.6	1.9	2.0
64.0													1.2	1.4	
68.0														0.9	

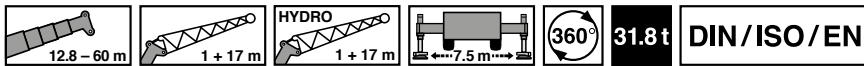

m	12.8 m + 1.0 m + 17.0 m			21.4 m + 1.0 m + 17.0 m			34.4 m + 1.0 m + 17.0 m			47.4 m + 1.0 m + 17.0 m			60.0 m + 1.0 m + 17.0 m		
	0°	20°	40°	0°	20°	40°	0°	20°	40°	0°	20°	40°	0°	20°	40°
3.0	7.8														
3.5	7.8														
4.0	7.8			7.4											
4.5	7.8			7.4											
5.0	7.8			7.4											
6.0	7.6			7.4			6.4			6.4					
7.0	7.2			7.4			6.4			6.4					
8.0	6.7			7.3			6.4			6.4					
9.0	6.3	5.1		7.0			6.4			6.4					
10.0	6.0	4.8		6.6	5.0		6.4			6.4			3.6		
11.0	5.6	4.6		6.3	4.8		6.4	4.8		6.4	4.8		3.6		
12.0	5.3	4.4		6.1	4.6		6.4	4.7		6.4	4.7		3.6		
14.0	4.8	4.0	3.5	5.5	4.3		6.0	4.4		6.0	4.4		3.6		
16.0	4.3	3.7	3.3	5.1	4.0	3.4	5.7	4.2	3.4	5.7	4.2	3.4	3.6		
18.0	4.0	3.4	3.1	4.7	3.8	3.2	5.3	4.0	3.3	5.3	4.0	3.3	3.6	3.6	
20.0	3.7	3.2	3.0	4.4	3.5	3.1	5.0	3.8	3.2	5.0	3.8	3.2	3.6	3.5	
22.0	3.4	3.1	2.9	4.1	3.4	3.0	4.7	3.6	3.1	4.7	3.6	3.1	3.6	3.4	
24.0	3.2	2.9	2.8	3.8	3.2	2.9	4.4	3.5	3.0	4.4	3.5	3.0	3.6	3.3	2.8
26.0	3.0	2.8	2.8	3.6	3.1	2.8	4.2	3.3	2.9	4.2	3.3	2.9	3.6	3.2	2.8
28.0	2.9	2.8		3.4	3.0	2.8	4.0	3.2	2.8	4.0	3.2	2.8	3.6	3.1	2.7
30.0				3.2	2.9	2.7	3.8	3.1	2.8	3.8	3.1	2.8	3.6	3.0	2.7
32.0				3.1	2.8	2.7	3.6	3.0	2.7	3.6	3.0	2.7	3.5	2.9	2.6
34.0				3.0	2.7		3.5	2.9	2.7	3.5	2.9	2.7	3.4	2.9	2.5
36.0				2.9	2.7		3.3	2.8	2.6	3.3	2.8	2.6	3.2	2.8	2.5
38.0							3.2	2.8	2.6	3.2	2.8	2.6	3.1	2.7	2.5
40.0							3.1	2.7	2.6	3.1	2.7	2.6	3.0	2.7	2.4
44.0							2.9	2.6	2.5	2.9	2.6	2.5	2.8	2.6	2.3
48.0							2.8	2.6		2.8	2.6		2.1	2.4	2.3
52.0													1.5	1.9	2.2
56.0													1.0	1.3	1.5
60.0															1.0

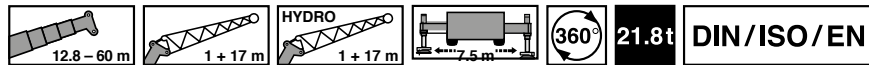

m	12.8 m + 1.0 m + 17.0 m			21.4 m + 1.0 m + 17.0 m			34.4 m + 1.0 m + 17.0 m			47.4 m + 1.0 m + 17.0 m			60.0 m + 1.0 m + 17.0 m		
	0°	20°	40°	0°	20°	40°	0°	20°	40°	0°	20°	40°	0°	20°	40°
3.0	7.8														
3.5	7.8														
4.0	7.8			7.4											
4.5	7.8			7.4											
5.0	7.8			7.4											
6.0	7.6			7.4			6.4								
7.0	7.2			7.4			6.4			4.7					
8.0	6.7			7.3			6.4			4.7					
9.0	6.3	5.1		7.0			6.4			4.7					
10.0	6.0	4.8		6.6	5.0		6.4			4.7			3.6		
11.0	5.6	4.6		6.3	4.8		6.4	4.8		4.7			3.6		
12.0	5.3	4.4		6.1	4.6		6.4	4.7		4.7			3.6		
14.0	4.8	4.0	3.5	5.5	4.3		6.0	4.4		4.7	4.2		3.6		
16.0	4.3	3.7	3.3	5.1	4.0	3.4	5.7	4.2	3.4	4.7	4.1		3.6		
18.0	4.0	3.4	3.1	4.7	3.8	3.2	5.3	4.0	3.3	4.7	3.9		3.6	3.6	
20.0	3.7	3.2	3.0	4.4	3.5	3.1	5.0	3.8	3.2	4.7	3.7	3.1	3.6	3.5	
22.0	3.4	3.1	2.9	4.1	3.4	3.0	4.7	3.6	3.1	4.7	3.6	3.0	3.6	3.4	
24.0	3.2	2.9	2.8	3.8	3.2	2.9	4.4	3.5	3.0	4.5	3.5	2.9	3.6	3.3	2.8
26.0	3.0	2.8	2.8	3.6	3.1	2.8	4.2	3.3	2.9	4.3	3.3	2.9	3.6	3.2	2.8
28.0	2.9	2.8		3.4	3.0	2.8	4.0	3.2	2.8	4.2	3.2	2.8	3.6	3.1	2.7
30.0				3.2	2.9	2.7	3.8	3.1	2.8	4.0	3.1	2.7	3.6	3.0	2.7
32.0				3.1	2.8	2.7	3.6	3.0	2.7	3.8	3.0	2.7	3.5	2.9	2.6
34.0				3.0	2.7		3.5	2.9	2.7	3.6	3.0	2.6	3.4	2.9	2.5
36.0				2.9	2.7		3.3	2.8	2.6	3.5	2.9	2.6	3.2	2.8	2.5
38.0							3.2	2.8	2.6	3.3	2.8	2.5	2.7	2.7	2.5
40.0							3.0	2.7	2.6	3.0	2.7	2.5	2.2	2.7	2.4
44.0							2.9	2.6	2.5	2.3	2.6	2.4	1.5	2.0	2.3
48.0							2.5	2.5		1.7	2.0	2.2		1.3	1.6
52.0										1.1	1.4	1.5			1.0
56.0											0.9				

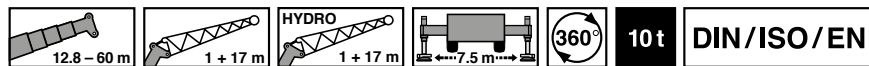

m	12.8 m + 1.0 m + 17.0 m			21.4 m + 1.0 m + 17.0 m			34.4 m + 1.0 m + 17.0 m			47.4 m + 1.0 m + 17.0 m			60.0 m + 1.0 m + 17.0 m		
	0°	20°	40°	0°	20°	40°	0°	20°	40°	0°	20°	40°	0°	20°	40°
3.0	7.8														
3.5	7.8														
4.0	7.8			7.4											
4.5	7.8			7.4											
5.0	7.8			7.4											
6.0	7.6			7.4			6.4								
7.0	7.2			7.4			6.4			4.7					
8.0	6.7			7.3			6.4			4.7					
9.0	6.3	5.1		7.0			6.4			4.7					
10.0	6.0	4.8		6.6	5.0		6.4			4.7			3.6		
11.0	5.6	4.6		6.3	4.8		6.4	4.8		4.7			3.6		
12.0	5.3	4.4		6.1	4.6		6.4	4.7		4.7			3.6		
14.0	4.8	4.0	3.5	5.5	4.3		6.0	4.4		4.7	4.2		3.6		
16.0	4.3	3.7	3.3	5.1	4.0	3.4	5.7	4.2	3.4	4.7	4.1		3.6		
18.0	4.0	3.4	3.1	4.7	3.8	3.2	5.3	4.0	3.3	4.7	3.9		3.6	3.6	
20.0	3.7	3.2	3.0	4.4	3.5	3.1	5.0	3.8	3.2	4.7	3.7	3.1	3.6	3.5	
22.0	3.4	3.1	2.9	4.1	3.4	3.0	4.7	3.6	3.1	4.7	3.6	3.0	3.6	3.4	
24.0	3.2	2.9	2.8	3.8	3.2	2.9	4.4	3.5	3.0	4.4	3.5	2.9	3.6	3.3	2.8
26.0	3.0	2.8	2.8	3.6	3.1	2.8	4.1	3.3	2.9	4.2	3.3	2.9	3.5	3.2	2.8
28.0	2.9	2.8		3.4	3.0	2.8	3.9	3.2	2.8	3.9	3.2	2.8	2.9	3.1	2.7
30.0				3.2	2.9	2.7	3.7	3.1	2.8	3.5	3.1	2.7	2.3	3.0	2.7
32.0				3.1	2.8	2.7	3.5	3.0	2.7	2.9	3.0	2.7	1.8	2.7	2.6
34.0				3.0	2.7		3.2	2.9	2.6	2.4	2.9	2.6		2.2	2.5
36.0				2.9	2.7		2.8	2.8	2.6	1.9	2.5	2.6		1.7	2.3
38.0							2.4	2.7	2.5	1.6	2.1	2.5			1.9
40.0							2.0	2.4	2.5	1.2	1.7	2.1			
44.0							1.5	1.7	1.8		1.0	1.3			
48.0							1.0	1.1							

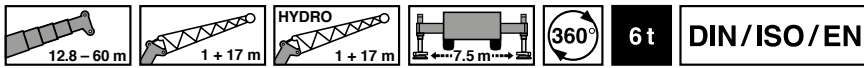

 m	12.8 m + 1.0 m + 17.0 m			21.4 m + 1.0 m + 17.0 m			34.4 m + 1.0 m + 17.0 m			47.4 m + 1.0 m + 17.0 m			60.0 m + 1.0 m + 17.0 m		
	0°	20°	40°	0°	20°	40°	0°	20°	40°	0°	20°	40°	0°	20°	40°
3.0	7.8														
3.5	7.8														
4.0	7.8			7.4											
4.5	7.8			7.4											
5.0	7.8			7.4											
6.0	7.6			7.4			6.4								
7.0	7.2			7.4			6.4			4.7					
8.0	6.7			7.3			6.4			4.7					
9.0	6.3	5.1		7.0			6.4			4.7					
10.0	6.0	4.8		6.6	5.0		6.4			4.7			3.6		
11.0	5.6	4.6		6.3	4.8		6.4	4.8		4.7			3.6		
12.0	5.3	4.4		6.1	4.6		6.4	4.7		4.7			3.6		
14.0	4.8	4.0	3.5	5.5	4.3		6.0	4.4		4.7	4.2		3.6		
16.0	4.3	3.7	3.3	5.1	4.0	3.4	5.7	4.2	3.4	4.7	4.1		3.6		
18.0	4.0	3.4	3.1	4.7	3.8	3.2	5.3	4.0	3.3	4.7	3.9		3.6	3.6	
20.0	3.7	3.2	3.0	4.4	3.5	3.1	5.0	3.8	3.2	4.7	3.7	3.1	3.6	3.5	
22.0	3.4	3.1	2.9	4.1	3.4	3.0	4.6	3.6	3.1	4.3	3.6	3.0	3.6	3.4	
24.0	3.2	2.9	2.8	3.8	3.2	2.9	4.4	3.5	3.0	3.9	3.5	2.9	3.2	3.3	2.8
26.0	3.0	2.8	2.8	3.6	3.1	2.8	4.0	3.3	2.9	3.8	3.3	2.9	2.5	3.2	2.8
28.0	2.9	2.8		3.4	3.0	2.8	3.8	3.2	2.8	3.2	3.2	2.8	1.9	2.9	2.7
30.0				3.2	2.9	2.7	3.5	3.1	2.8	2.6	3.0	2.7		2.3	2.7
32.0				3.1	2.8	2.7	2.9	2.9	2.7	2.1	2.8	2.7		1.8	2.5
34.0				2.7	2.7		2.5	2.8	2.6	1.6	2.3	2.6			2.0
36.0				2.3	2.5		2.1	2.5	2.5	1.2	1.8	2.3			
38.0							1.7	2.1	2.4	0.9	1.4	1.8			
40.0							1.4	1.7	1.9		1.1	1.4			
44.0							0.9	1.1	1.2						

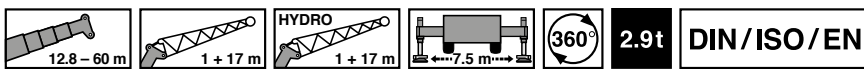

 m	12.8 m + 1.0 m + 17.0 m			21.4 m + 1.0 m + 17.0 m			34.4 m + 1.0 m + 17.0 m			47.4 m + 1.0 m + 17.0 m			60.0 m + 1.0 m + 17.0 m		
	0°	20°	40°	0°	20°	40°	0°	20°	40°	0°	20°	40°	0°	20°	40°
3.0	7.8														
3.5	7.8														
4.0	7.8			7.4											
4.5	7.8			7.4											
5.0	7.8			7.4											
6.0	7.6			7.4			6.4								
7.0	7.2			7.4			6.4			4.7					
8.0	6.7			7.3			6.4			4.7					
9.0	6.3	5.1		7.0			6.4			4.7					
10.0	6.0	4.8		6.6	5.0		6.4			4.7			3.6		
11.0	5.6	4.6		6.3	4.8		6.4	4.8		4.7			3.6		
12.0	5.3	4.4		6.1	4.6		6.4	4.7		4.7			3.6		
14.0	4.8	4.0	3.5	5.5	4.3		6.0	4.4		4.7	4.2		3.6		
16.0	4.3	3.7	3.3	5.1	4.0	3.4	5.7	4.2	3.4	4.7	4.1		3.6		
18.0	4.0	3.4	3.1	4.7	3.8	3.2	5.3	4.0	3.3	4.7	3.9		3.6	3.6	
20.0	3.7	3.2	3.0	4.4	3.5	3.1	4.9	3.8	3.2	4.3	3.7	3.1	3.6	3.5	
22.0	3.4	3.1	2.9	4.1	3.4	3.0	4.6	3.6	3.1	3.9	3.6	3.0	3.0	3.4	
24.0	3.2	2.9	2.8	3.8	3.2	2.9	4.2	3.5	3.0	3.6	3.5	2.9	2.3	3.3	2.8
26.0	3.0	2.8	2.8	3.6	3.1	2.8	4.0	3.3	2.9	2.9	3.3	2.9		2.7	2.8
28.0	2.9	2.8		3.4	3.0	2.8	3.3	3.2	2.8	2.4	3.1	2.8		2.1	2.7
30.0				3.0	2.9	2.7	2.7	3.0	2.7	1.9	2.6	2.7			2.4
32.0				2.5	2.8	2.7	2.3	2.8	2.6	1.4	2.1	2.6			
34.0				2.1	2.4		1.9	2.3	2.6		1.7	2.2			
36.0				1.8	1.9		1.5	1.9	2.2		1.2	1.7			
38.0							1.2	1.5	1.8			1.3			
40.0							0.9	1.2	1.4						

Operation · Einsatz · Utilisation  
 Uso · Эксплуатация

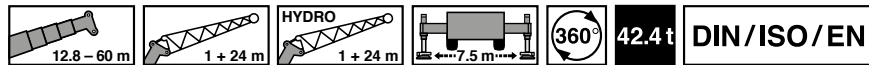

m	12.8 m + 1.0 m + 24.0 m			21.4 m + 1.0 m + 24.0 m			34.4 m + 1.0 m + 24.0 m			47.4 m + 1.0 m + 24.0 m			60.0 m + 1.0 m + 24.0 m		
	0°	20°	40°	0°	20°	40°	0°	20°	40°	0°	20°	40°	0°	20°	40°
4.0	5.1														
4.5	5.1														
5.0	5.1			4.9											
6.0	5.1			4.9			4.2								
7.0	5.1			4.9			4.2								
8.0	5.1			4.9			4.2			3.3					
9.0	5.1			4.9			4.2			3.3					
10.0	5.1			4.9			4.2			3.3					
11.0	5.1			4.9			4.2			3.3				2.7	
12.0	5.1	4.7		4.9			4.2			3.3				2.7	
14.0	5.0	4.4		4.9	4.4		4.2			3.3				2.7	
16.0	4.6	4.0		4.9	4.1		4.2	4.1		3.3				2.7	
18.0	4.1	3.7		4.7	3.9		4.2	3.9		3.3	3.3			2.7	
20.0	3.6	3.3	2.9	4.5	3.7	3.0	4.2	3.8		3.3	3.3			2.7	
22.0	3.2	3.1	2.7	4.1	3.5	2.8	4.2	3.6		3.3	3.3			2.7	2.7
24.0	2.9	2.8	2.5	3.7	3.2	2.7	4.2	3.5	2.8	3.3	3.3			2.7	2.7
26.0	2.6	2.6	2.3	3.4	3.0	2.5	4.1	3.3	2.7	3.3	3.2	2.7		2.7	2.7
28.0	2.4	2.4	2.2	3.1	2.8	2.4	3.9	3.2	2.6	3.3	3.2	2.6		2.7	2.7
30.0	2.2	2.3	2.1	2.8	2.7	2.3	3.7	3.1	2.5	3.3	3.1	2.5		2.7	2.6
32.0	2.0	2.2	2.0	2.6	2.5	2.2	3.4	2.9	2.4	3.3	3.0	2.5		2.7	2.5
34.0	1.9	2.1		2.4	2.4	2.1	3.2	2.8	2.3	3.3	2.9	2.4		2.7	2.4
36.0				2.3	2.3	2.1	3.0	2.7	2.2	3.3	2.8	2.3		2.6	2.3
38.0				2.1	2.2	2.0	2.8	2.5	2.2	3.3	2.8	2.3		2.5	2.2
40.0				2.0	2.1	2.0	2.6	2.4	2.1	3.1	2.7	2.2		2.4	2.1
44.0				1.8			2.3	2.3	2.0	2.8	2.5	2.1		2.2	2.0
48.0							2.1	2.1	2.0	2.5	2.4	2.1		2.1	1.8
52.0							1.9	2.0		2.3	2.2	2.0		1.9	1.7
56.0							1.8	2.0		2.1	2.1	1.9		1.8	1.6
60.0										1.9	2.0	1.9		1.7	1.5
64.0										1.6	1.9	1.9		1.2	1.5
68.0										1.3	1.4			1.1	1.3

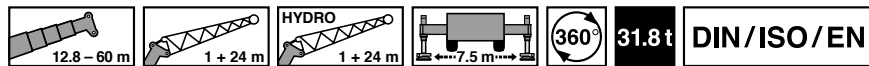

m	12.8 m + 1.0 m + 24.0 m			21.4 m + 1.0 m + 24.0 m			34.4 m + 1.0 m + 24.0 m			47.4 m + 1.0 m + 24.0 m			60.0 m + 1.0 m + 24.0 m		
	0°	20°	40°	0°	20°	40°	0°	20°	40°	0°	20°	40°	0°	20°	40°
4.0	5.1														
4.5	5.1														
5.0	5.1			4.9											
6.0	5.1			4.9			4.2								
7.0	5.1			4.9			4.2								
8.0	5.1			4.9			4.2			3.3					
9.0	5.1			4.9			4.2			3.3					
10.0	5.1			4.9			4.2			3.3					
11.0	5.1			4.9			4.2			3.3				2.7	
12.0	5.1	4.7		4.9			4.2			3.3				2.7	
14.0	5.0	4.4		4.9	4.4		4.2			3.3				2.7	
16.0	4.6	4.0		4.9	4.1		4.2	4.1		3.3				2.7	
18.0	4.1	3.7		4.7	3.9		4.2	3.9		3.3	3.3			2.7	
20.0	3.6	3.3	2.9	4.5	3.7	3.0	4.2	3.8		3.3	3.3			2.7	
22.0	3.2	3.1	2.7	4.1	3.5	2.8	4.2	3.6		3.3	3.3			2.7	2.7
24.0	2.9	2.8	2.5	3.7	3.2	2.7	4.2	3.5	2.8	3.3	3.3			2.7	2.7
26.0	2.6	2.6	2.3	3.4	3.0	2.5	4.1	3.3	2.7	3.3	3.2	2.7		2.7	2.7
28.0	2.4	2.4	2.2	3.1	2.8	2.4	3.9	3.2	2.6	3.3	3.2	2.6		2.7	2.7
30.0	2.2	2.3	2.1	2.8	2.7	2.3	3.7	3.1	2.5	3.3	3.1	2.5		2.7	2.6
32.0	2.0	2.2	2.0	2.6	2.5	2.2	3.4	2.9	2.4	3.3	3.0	2.5		2.7	2.5
34.0	1.9	2.1		2.4	2.4	2.1	3.2	2.8	2.3	3.3	2.9	2.4		2.7	2.4
36.0				2.3	2.3	2.1	3.0	2.7	2.2	3.3	2.8	2.3		2.6	2.3
38.0				2.1	2.2	2.0	2.8	2.5	2.2	3.3	2.8	2.3		2.5	2.2
40.0				2.0	2.1	2.0	2.6	2.4	2.1	3.1	2.7	2.2		2.4	2.1
44.0				1.8			2.3	2.3	2.0	2.8	2.5	2.1		2.2	2.0
48.0							2.1	2.1	2.0	2.5	2.4	2.1		2.1	1.8
52.0							1.9	2.0		2.2	2.2	2.0		1.6	1.7
56.0							1.8	2.0		1.9	1.9	1.9		1.0	1.5
60.0										1.4	1.7	1.7		1.0	1.5
64.0										1.0	1.2			1.0	1.3

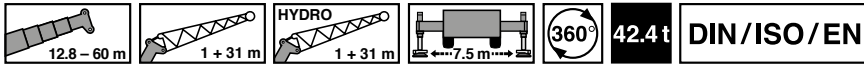

m	12.8 m + 1.0 m + 31.0 m			21.4 m + 1.0 m + 31.0 m			34.4 m + 1.0 m + 31.0 m			47.4 m + 1.0 m + 31.0 m			60.0 m + 1.0 m + 31.0 m		
	0°	20°	40°	0°	20°	40°	0°	20°	40°	0°	20°	40°	0°	20°	40°
5.0	3.5														
6.0	3.5			3.3											
7.0	3.5			3.3			2.9								
8.0	3.5			3.3			2.9								
9.0	3.5			3.3			2.9			2.4					
10.0	3.5			3.3			2.9			2.4					
11.0	3.5			3.3			2.9			2.4					
12.0	3.5			3.3			2.9			2.4					
14.0	3.5			3.3			2.9			2.4			2.0		
16.0	3.5	3.4		3.3			2.9			2.4			2.0		
18.0	3.4	3.0		3.3	3.2		2.9			2.4			2.0		
20.0	3.0	2.7		3.3	3.0		2.9	2.9		2.4			2.0		
22.0	2.6	2.5		3.2	2.7		2.9	2.9		2.4	2.4		2.0		
24.0	2.3	2.3	1.9	2.9	2.5		2.9	2.7		2.4	2.4		2.0		
26.0	2.1	2.1	1.8	2.6	2.3	1.9	2.9	2.6		2.4	2.4		2.0		
28.0	1.9	1.9	1.7	2.4	2.2	1.8	2.9	2.4	1.8	2.4	2.4		2.0	2.0	
30.0	1.7	1.8	1.6	2.1	2.0	1.7	2.8	2.3	1.7	2.4	2.4		2.0	2.0	
32.0	1.5	1.6	1.5	2.0	1.9	1.6	2.5	2.1	1.7	2.4	2.2	1.7	2.0	1.9	
34.0	1.4	1.5	1.4	1.8	1.8	1.5	2.3	2.0	1.6	2.4	2.1	1.6	2.0	1.9	
36.0	1.3	1.4	1.3	1.6	1.7	1.4	2.2	1.9	1.5	2.4	2.0	1.6	2.0	1.8	
38.0	1.1	1.3	1.2	1.5	1.6	1.4	2.0	1.8	1.5	2.4	2.0	1.5	1.9	1.7	1.5
40.0	1.0	1.3	1.2	1.4	1.5	1.3	1.9	1.7	1.4	2.2	1.9	1.5	1.9	1.6	1.4
44.0				1.2	1.3	1.2	1.6	1.6	1.3	2.0	1.7	1.4	1.7	1.5	1.3
48.0				1.0	1.2	1.2	1.4	1.5	1.3	1.7	1.6	1.3	1.6	1.4	1.3
52.0							1.3	1.3	1.2	1.5	1.5	1.2	1.5	1.3	1.2
56.0							1.1	1.3	1.2	1.4	1.4	1.1	1.3	1.2	1.1
60.0							1.0	1.2		1.3	1.3	1.1	1.2	1.1	1.0
64.0							0.9			1.1	1.2	1.1	1.1	1.0	0.9
68.0										1.0	1.2			0.9	
72.0										0.9	1.1				

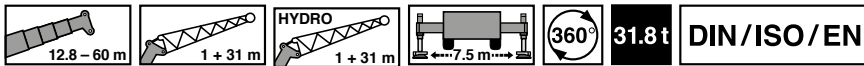

m	12.8 m + 1.0 m + 31.0 m			21.4 m + 1.0 m + 31.0 m			34.4 m + 1.0 m + 31.0 m			47.4 m + 1.0 m + 31.0 m			60.0 m + 1.0 m + 31.0 m		
	0°	20°	40°	0°	20°	40°	0°	20°	40°	0°	20°	40°	0°	20°	40°
5.0	3.5														
6.0	3.5			3.3											
7.0	3.5			3.3			2.9								
8.0	3.5			3.3			2.9								
9.0	3.5			3.3			2.9			2.4					
10.0	3.5			3.3			2.9			2.4					
11.0	3.5			3.3			2.9			2.4					
12.0	3.5			3.3			2.9			2.4					
14.0	3.5			3.3			2.9			2.4			2.0		
16.0	3.5	3.4		3.3			2.9			2.4			2.0		
18.0	3.4	3.0		3.3	3.2		2.9			2.4			2.0		
20.0	3.0	2.7		3.3	3.0		2.9	2.9		2.4			2.0		
22.0	2.6	2.5		3.2	2.7		2.9	2.9		2.4	2.4		2.0		
24.0	2.3	2.3	1.9	2.9	2.5		2.9	2.7		2.4	2.4		2.0		
26.0	2.1	2.1	1.8	2.6	2.3	1.9	2.9	2.6		2.4	2.4		2.0		
28.0	1.9	1.9	1.7	2.4	2.2	1.8	2.9	2.4	1.8	2.4	2.4		2.0	2.0	
30.0	1.7	1.8	1.6	2.1	2.0	1.7	2.8	2.3	1.7	2.4	2.4		2.0	2.0	
32.0	1.5	1.6	1.5	2.0	1.9	1.6	2.5	2.1	1.7	2.4	2.2	1.7	2.0	1.9	
34.0	1.4	1.5	1.4	1.8	1.8	1.5	2.3	2.0	1.6	2.4	2.1	1.6	2.0	1.9	
36.0	1.3	1.4	1.3	1.6	1.7	1.4	2.2	1.9	1.5	2.4	2.0	1.6	2.0	1.8	
38.0	1.1	1.3	1.2	1.5	1.6	1.4	2.0	1.8	1.5	2.4	2.0	1.5	1.9	1.7	1.5
40.0	1.0	1.3	1.2	1.4	1.5	1.3	1.9	1.7	1.4	2.2	1.9	1.5	1.9	1.6	1.4
44.0				1.2	1.3	1.2	1.6	1.6	1.3	2.0	1.7	1.4	1.7	1.5	1.3
48.0				1.0	1.2	1.2	1.4	1.5	1.3	1.7	1.6	1.3	1.6	1.4	1.3
52.0							1.3	1.3	1.2	1.5	1.5	1.2	1.5	1.3	1.2
56.0							1.1	1.3	1.2	1.4	1.4	1.1	1.1	1.2	1.1
60.0							1.0	1.2		1.2	1.3	1.1		1.1	1.0
64.0							0.9			1.0	1.1	1.1			0.9
68.0											1.0				

Operation · Einsatz · Utilisation  
 Uso · Эксплуатация

Working range · Arbeitsbereich · Rayon de travail  
 Zona de trabajo · Area di lavoro · Рабочая зона

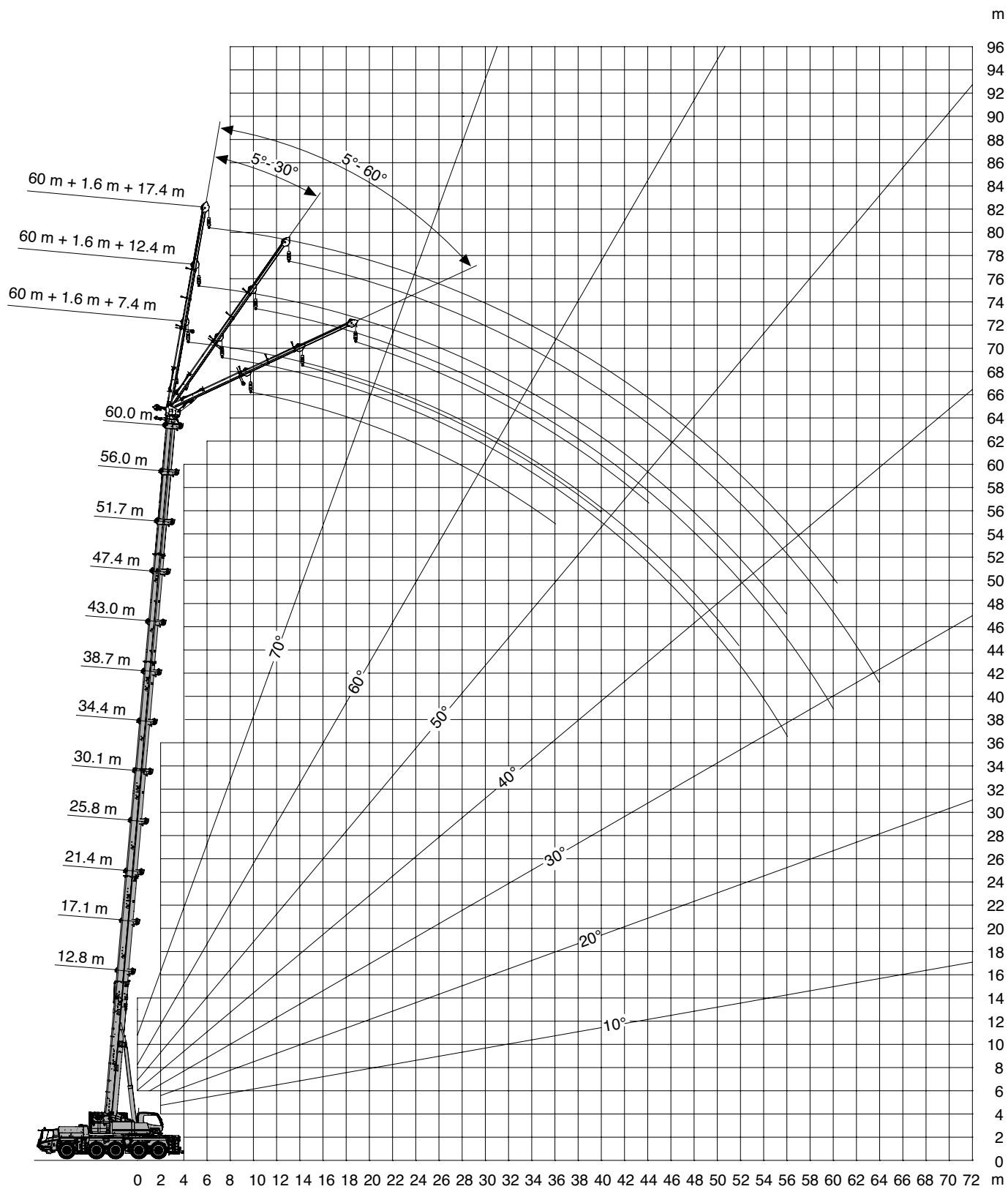
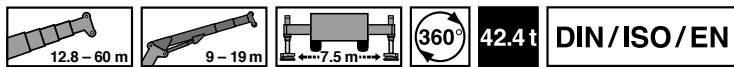

Lifting capacities · Traglasten · Charges de levage  
 Cargas · Portate · Грузоподъемность

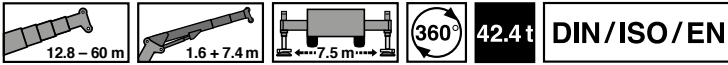

m	12.8 m + 1.6 m + 7.4 m			21.4 m + 1.6 m + 7.4 m			34.4 m + 1.6 m + 7.4 m			47.4 m + 1.6 m + 7.4 m			60.0 m + 1.6 m + 7.4 m		
	5°	30°	60°	5°	30°	60°	5°	30°	60°	5°	30°	60°	5°	30°	60°
3.0	7.3														
3.5	7.3			7.3											
4.0	7.3			7.3											
4.5	7.3			7.3			7.3								
5.0	7.3			7.3			7.3								
6.0	7.3	7.3		7.3	7.3		7.3								
7.0	7.3	7.3		7.3	7.3		7.3			7.3					
8.0	7.3	7.0	4.4	7.3	7.3		7.3	7.3		7.3					
9.0	7.3	6.6	4.4	7.3	7.3	4.5	7.3	7.3		7.3			5.4		
10.0	7.3	6.3	4.3	7.3	7.2	4.4	7.3	7.3	4.5	7.3	7.3		5.4		
11.0	7.3	6.1	4.3	7.3	7.0	4.4	7.3	7.3	4.5	7.3	7.3		5.4		
12.0	7.1	5.8	4.3	7.3	6.7	4.3	7.3	7.3	4.4	7.3	7.3	4.5	5.4		
14.0	6.1	5.4		7.3	6.3	4.3	7.3	7.2	4.4	7.3	7.3	4.4	5.4	5.4	5.4
16.0	5.4	5.2		7.3	5.9	4.2	7.3	6.8	4.3	7.3	7.3	4.4	5.4	5.4	5.4
18.0	4.9			6.9	5.6		7.3	6.5	4.3	7.3	7.1	4.3	5.4	5.3	5.3
20.0				6.2	5.4		7.3	6.2	4.2	7.3	6.9	4.3	5.4	5.1	5.1
22.0				5.7	5.2		7.3	6.0	4.2	7.3	6.6	4.2	5.1	4.8	4.8
24.0				5.2	5.1		7.3	5.7	4.2	7.3	6.4	4.2	4.8	4.6	4.6
26.0				4.8			7.0	5.6		7.2	6.2	4.2	4.6	4.4	4.4
28.0				4.6			6.5	5.4		6.9	6.0	4.2	4.3	4.2	4.2
30.0							6.0	5.3		6.5	5.8	4.2	4.1	4.0	4.0
32.0							5.7	5.2		6.1	5.6		3.9	3.8	3.8
34.0							5.3	5.1		5.7	5.5		3.7	3.6	3.6
36.0							5.1	5.1		5.2	5.4		3.5	3.4	3.4
38.0							4.8			4.5	4.7		3.3	3.2	3.2
40.0							4.5			4.1	4.1		3.0	3.0	3.0
44.0										3.3	3.5		2.7	2.6	2.6
48.0										2.4	2.5		2.2	2.3	2.3
52.0										1.7			1.4	1.6	1.6
56.0													0.9	0.9	0.9

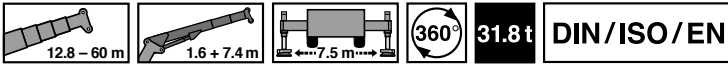

m	12.8 m + 1.6 m + 7.4 m			21.4 m + 1.6 m + 7.4 m			34.4 m + 1.6 m + 7.4 m			47.4 m + 1.6 m + 7.4 m			60.0 m + 1.6 m + 7.4 m		
	5°	30°	60°	5°	30°	60°	5°	30°	60°	5°	30°	60°	5°	30°	60°
3.0	7.3														
3.5	7.3			7.3											
4.0	7.3			7.3											
4.5	7.3			7.3			7.3								
5.0	7.3			7.3			7.3								
6.0	7.3	7.3		7.3	7.3		7.3								
7.0	7.3	7.3		7.3	7.3		7.3			7.3	7.3				
8.0	7.3	7.0	4.4	7.3	7.3		7.3	7.3		7.3	7.3				
9.0	7.3	6.6	4.4	7.3	7.3	4.5	7.3	7.3		7.3	7.3		5.4		
10.0	7.3	6.3	4.3	7.3	7.2	4.4	7.3	7.3	4.5	7.3	7.3		5.4		
11.0	7.3	6.1	4.3	7.3	7.0	4.4	7.3	7.3	4.5	7.3	7.3		5.4		
12.0	7.1	5.8	4.3	7.3	6.7	4.3	7.3	7.3	4.4	7.3	7.3	4.5	5.4		
14.0	6.1	5.4		7.3	6.3	4.3	7.3	7.2	4.4	7.3	7.3	4.4	5.4	5.4	
16.0	5.4	5.2		7.3	5.9	4.2	7.3	6.8	4.3	7.3	7.3	4.4	5.4	5.4	4.4
18.0	4.9			6.9	5.6		7.3	6.5	4.3	7.3	7.3	4.3	5.4	5.3	4.4
20.0				6.2	5.4		7.3	6.2	4.2	7.3	7.3	4.3	5.4	5.1	4.3
22.0				5.7	5.2		7.3	6.0	4.2	7.3	7.3	4.2	5.1	4.8	4.3
24.0				5.2	5.1		7.3	5.7	4.2	7.3	7.3	4.2	4.8	4.6	4.3
26.0				4.8			7.0	5.6		7.2	7.2	4.2	4.6	4.4	4.2
28.0				4.6			6.5	5.4		6.7	6.7	4.2	4.3	4.2	4.1
30.0							6.0	5.3		5.7	5.7	4.2	4.1	4.0	3.9
32.0							5.6	5.2		5.3	5.3		3.9	3.8	3.8
34.0							4.9	5.0		4.6	4.6		3.7	3.6	3.6
36.0							4.2	4.3		4.0	4.0		3.5	3.4	3.4
38.0							3.5			3.7	3.7		3.0	3.2	
40.0							3.0			3.3	3.3		2.5	2.8	
44.0										2.3	2.3		1.6	1.8	
48.0										1.6	1.6		1.0	1.0	
52.0										1.0	1.0				

Operation · Einsatz · Utilisation  
 Uso · Эксплуатация

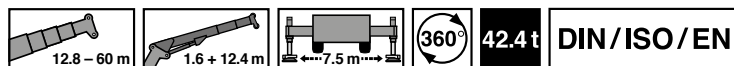

m	12.8 m + 1.6 m + 12.4 m			21.4 m + 1.6 m + 12.4 m			34.4 m + 1.6 m + 12.4 m			47.4 m + 1.6 m + 12.4 m			60.0 m + 1.6 m + 12.4 m		
	5°	30°	60°	5°	30°	60°	5°	30°	60°	5°	30°	60°	5°	30°	60°
3.5	4.3														
4.0	4.3														
4.5	4.3			4.3											
5.0	4.3			4.3											
6.0	4.3			4.3			4.3								
7.0	4.3			4.3			4.3								
8.0	4.3			4.3			4.3			4.3					
9.0	4.3	4.3		4.3	4.3		4.3			4.3					
10.0	4.3	4.1		4.3	4.3		4.3			4.3					
11.0	4.3	3.9		4.3	4.3		4.3	4.3		4.3			3.8		
12.0	4.3	3.7	2.4	4.3	4.1		4.3	4.3		4.3			3.8		
14.0	4.1	3.3	2.3	4.3	3.8	2.4	4.3	4.2		4.3	4.0		3.8		
16.0	3.6	3.1	2.3	4.3	3.5	2.3	4.3	3.9	2.4	4.3	3.9		3.8		
18.0	3.2	2.9		4.3	3.3	2.3	4.3	3.8	2.3	4.3	3.7	2.4	3.8	3.5	
20.0	2.9	2.7		3.9	3.1	2.3	4.3	3.6	2.3	4.3	3.6	2.3	3.8	3.4	2.3
22.0	2.6	2.6		3.5	2.9	2.3	4.3	3.4	2.3	4.3	3.5	2.3	3.8	3.3	2.3
24.0	2.4			3.2	2.8		4.3	3.2	2.2	4.3	3.4	2.3	3.8	3.2	2.3
26.0				3.0	2.7		4.1	3.1	2.2	4.3	3.2	2.2	3.8	3.1	2.3
28.0				2.7	2.6		3.8	3.0	2.2	4.3	3.2	2.2	3.8	3.0	2.2
30.0				2.6	2.6		3.6	2.9		4.1	3.1	2.2	3.7	3.0	2.2
32.0				2.4			3.3	2.8		4.0	3.0	2.2	3.5	2.9	2.2
34.0							3.1	2.7		3.8	2.9	2.2	3.4	2.8	2.2
36.0							3.0	2.6		3.7	2.8		3.2	2.7	2.2
38.0							2.8	2.6		3.5	2.8		3.0	2.7	2.2
40.0							2.7	2.6		3.4	2.7		2.8	2.6	2.2
44.0							2.4			3.1	2.6		2.4	2.4	
48.0										2.8	2.6		2.1	2.1	
52.0										2.3	2.4		1.9	1.9	
56.0										1.6			1.3	1.5	
60.0														0.9	

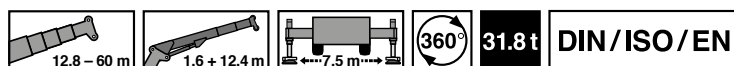

m	12.8 m + 1.6 m + 12.4 m			21.4 m + 1.6 m + 12.4 m			34.4 m + 1.6 m + 12.4 m			47.4 m + 1.6 m + 12.4 m			60.0 m + 1.6 m + 12.4 m		
	5°	30°	60°	5°	30°	60°	5°	30°	60°	5°	30°	60°	5°	30°	60°
3.5	4.3														
4.0	4.3														
4.5	4.3			4.3											
5.0	4.3			4.3											
6.0	4.3			4.3			4.3								
7.0	4.3			4.3			4.3								
8.0	4.3			4.3			4.3			4.3					
9.0	4.3	4.3		4.3	4.3		4.3			4.3					
10.0	4.3	4.1		4.3	4.3		4.3			4.3					
11.0	4.3	3.9		4.3	4.3		4.3	4.3		4.3			3.8		
12.0	4.3	3.7	2.4	4.3	4.1		4.3	4.3		4.3			3.8		
14.0	4.1	3.3	2.3	4.3	3.8	2.4	4.3	4.2		4.3	4.0	4.0	3.8		
16.0	3.6	3.1	2.3	4.3	3.5	2.3	4.3	3.9	2.4	4.3	3.9	3.9	3.8		
18.0	3.2	2.9		4.3	3.3	2.3	4.3	3.8	2.3	4.3	3.7	3.7	3.8	3.5	
20.0	2.9	2.7		3.9	3.1	2.3	4.3	3.6	2.3	4.3	3.6	3.6	3.8	3.4	2.3
22.0	2.6	2.6		3.5	2.9	2.3	4.3	3.4	2.3	4.3	3.5	3.5	3.8	3.3	2.3
24.0	2.4			3.2	2.8		4.3	3.2	2.2	4.3	3.4	3.4	3.8	3.2	2.3
26.0				3.0	2.7		4.1	3.1	2.2	4.3	3.2	3.2	3.8	3.1	2.3
28.0				2.7	2.6		3.8	3.0	2.2	4.3	3.2	3.2	3.8	3.0	2.2
30.0				2.6	2.6		3.6	2.9		4.1	3.1	3.1	3.7	3.0	2.2
32.0				2.4			3.3	2.8		4.0	3.0	3.0	3.5	2.9	2.2
34.0							3.1	2.7		3.8	2.9	2.9	3.4	2.8	2.2
36.0							3.0	2.6		3.7	2.8	2.8	3.2	2.7	2.2
38.0							2.8	2.6		3.5	2.8	2.8	3.0	2.7	2.2
40.0							2.7	2.6		3.3	2.7	2.7	2.8	2.6	2.2
44.0							2.4			2.9	2.6	2.6	2.1	2.4	
48.0										2.1	2.3	2.3	1.3	1.7	
52.0										1.5	1.6	1.6			
56.0										0.9					



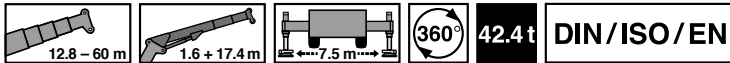

m	12.8 m + 1.6 m + 17.4 m			21.4 m + 1.6 m + 17.4 m			34.4 m + 1.6 m + 17.4 m			47.4 m + 1.6 m + 17.4 m			60.0 m + 1.6 m + 17.4 m		
	5°	30°	60°	5°	30°	60°	5°	30°	60°	5°	30°	60°	5°	30°	60°
4.5	3.3														
5.0	3.3														
6.0	3.3			3.3											
7.0	3.3			3.3			3.3								
8.0	3.3			3.3			3.3								
9.0	3.3			3.3			3.3								
10.0	3.3			3.3			3.3			3.2					
11.0	3.3			3.3			3.3			3.2					
12.0	3.3	2.6		3.3			3.3			3.2			2.6	2.6	
14.0	3.1	2.3		3.3	2.5		3.3			3.2			2.6	2.6	
16.0	2.8	2.1		3.2	2.3		3.3	2.4	2.4	3.2			2.6	2.6	
18.0	2.5	1.9	1.5	3.0	2.2	1.5	3.3	2.3	2.3	3.2	2.2		2.6	2.6	
20.0	2.3	1.8	1.5	2.8	2.0	1.5	3.1	2.2	2.2	3.2	2.2		2.6	2.6	
22.0	2.0	1.7	1.4	2.6	1.9	1.5	2.9	2.1	2.1	3.0	2.1		2.6	2.6	
24.0	1.8	1.6		2.4	1.8	1.4	2.8	2.0	2.0	2.9	2.0	1.5	2.6	2.6	
26.0	1.7	1.5		2.2	1.7	1.4	2.6	1.9	1.9	2.7	2.0	1.4	2.5	2.5	1.4
28.0	1.5	1.5		2.0	1.6		2.5	1.9	1.9	2.6	1.9	1.4	2.5	2.5	1.4
30.0				1.9	1.6		2.4	1.8	1.8	2.5	1.8	1.4	2.4	2.4	1.4
32.0				1.8	1.5		2.3	1.7	1.7	2.4	1.8	1.4	2.4	2.4	1.4
34.0				1.6	1.5		2.2	1.7	1.7	2.3	1.7	1.4	2.3	2.3	1.4
36.0				1.5	1.5		2.1	1.6	1.6	2.2	1.7	1.4	2.2	2.2	1.4
38.0				1.5			2.0	1.6	1.6	2.1	1.7	1.4	2.1	2.1	1.4
40.0							1.9	1.5	1.5	2.1	1.6	1.4	2.1	2.1	1.4
44.0							1.7	1.5	1.5	1.9	1.6		1.9	1.9	1.4
48.0							1.5			1.8	1.5		1.8	1.8	
52.0										1.7	1.5		1.7	1.7	
56.0										1.6	1.4		1.6	1.6	
60.0										1.5			1.2	1.2	

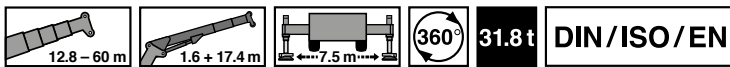

m	12.8 m + 1.6 m + 17.4 m			21.4 m + 1.6 m + 17.4 m			34.4 m + 1.6 m + 17.4 m			47.4 m + 1.6 m + 17.4 m			60.0 m + 1.6 m + 17.4 m		
	5°	30°	60°	5°	30°	60°	5°	30°	60°	5°	30°	60°	5°	30°	60°
4.5	3.3														
5.0	3.3														
6.0	3.3			3.3											
7.0	3.3			3.3			3.3								
8.0	3.3			3.3			3.3								
9.0	3.3			3.3			3.3								
10.0	3.3			3.3			3.3			3.2					
11.0	3.3			3.3			3.3			3.2					
12.0	3.3	2.6		3.3			3.3			3.2			2.6		
14.0	3.1	2.3		3.3	2.5		3.3			3.2			2.6		
16.0	2.8	2.1		3.2	2.3		3.3	2.4		3.2			2.6		
18.0	2.5	1.9	1.5	3.0	2.2	1.5	3.3	2.3		3.2	2.2		2.6		
20.0	2.3	1.8	1.5	2.8	2.0	1.5	3.1	2.2	1.5	3.2	2.2		2.6		
22.0	2.0	1.7	1.4	2.6	1.9	1.5	2.9	2.1	1.5	3.0	2.1		2.6	2.0	
24.0	1.8	1.6		2.4	1.8	1.4	2.8	2.0	1.5	2.9	2.0	1.5	2.6	2.0	
26.0	1.7	1.5		2.2	1.7	1.4	2.6	1.9	1.4	2.7	2.0	1.4	2.5	1.9	1.4
28.0	1.5	1.5		2.0	1.6		2.5	1.9	1.4	2.6	1.9	1.4	2.5	1.9	1.4
30.0				1.9	1.6		2.4	1.8	1.4	2.5	1.8	1.4	2.4	1.8	1.4
32.0				1.8	1.5		2.3	1.7	1.4	2.4	1.8	1.4	2.4	1.7	1.4
34.0				1.6	1.5		2.2	1.7	1.4	2.3	1.7	1.4	2.3	1.7	1.4
36.0				1.5	1.5		2.1	1.6		2.2	1.7	1.4	2.2	1.7	1.4
38.0				1.5			2.0	1.6		2.1	1.7	1.4	2.1	1.6	1.4
40.0							1.9	1.5		2.1	1.6	1.4	2.1	1.6	1.4
44.0							1.7	1.5		1.9	1.6		1.9	1.5	1.4
48.0							1.5			1.8	1.5		1.7	1.5	
52.0										1.7	1.5		1.1	1.4	
56.0										1.4	1.4			0.9	
60.0										0.9					

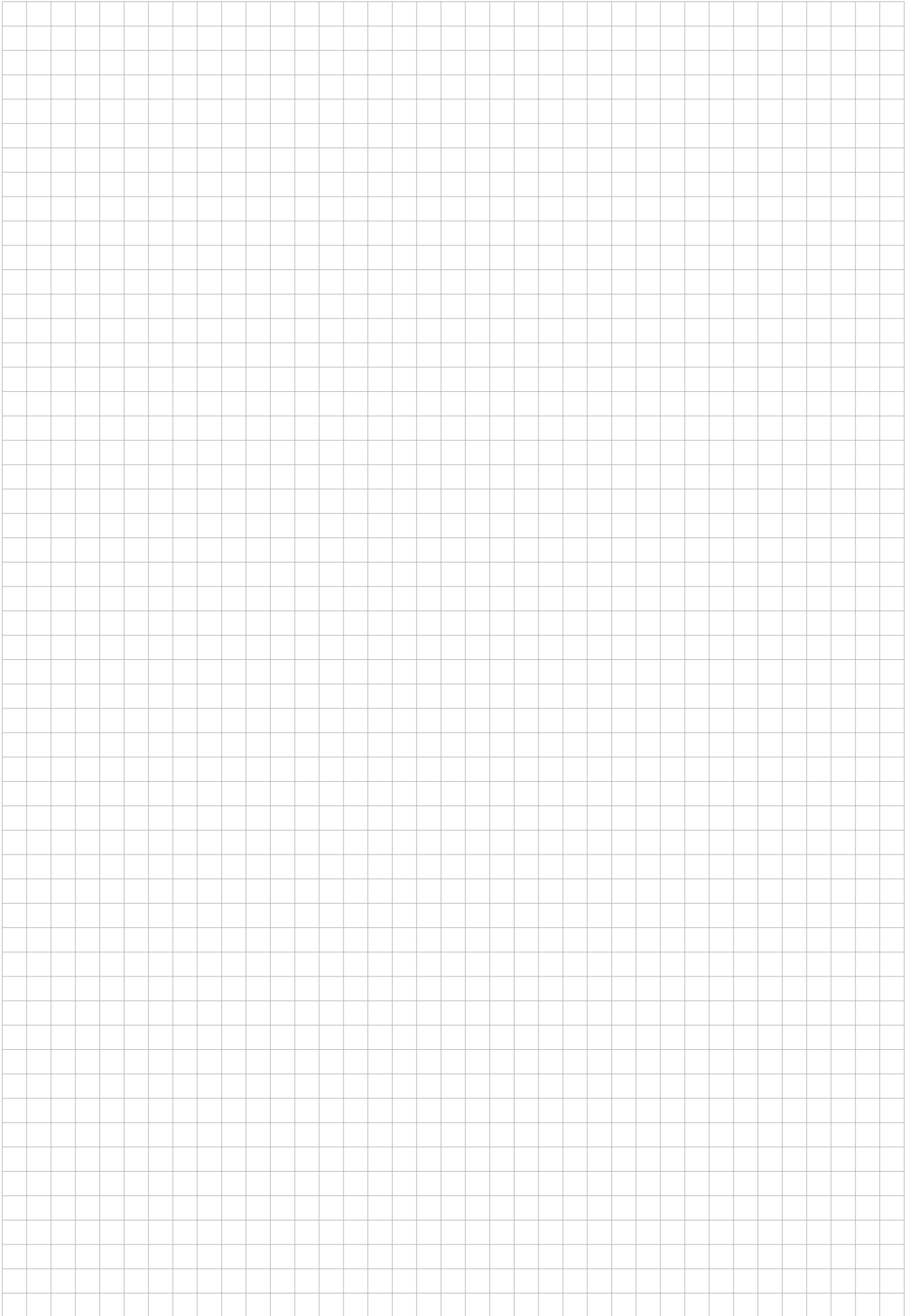

# EQUIPMENT

AUSSTATTUNG

ÉQUIPEMENT

EQUIPAMIENTO

EQUIPAGGIAMENTO

ОБОРУДОВАНИЕ



## Equipment

### Carrier

**Frame:** Torsion-resistant, welded construction made from high-strength, fine-grained steel. Central lubrication system.

**Outriggers:** 4-point double telescopic hydraulic outriggers incl. asymmetric outrigger base and automatic length detection. Controls on both side of carrier and in superstructure cab. Outrigger base 7.5 m (6.2 m / 5.0 m / 4.1 m / 2.5 m) x 8.03 m.

**Engine:** Mercedes-Benz 6 cylinder model OM 471 LA (Euromot IV / EPA Tier 4f), water-cooled diesel engine, engine displacement 12.8 l, rated at 390 kW (530 HP) at 1700 min<sup>-1</sup>. Torque 2460 Nm at 1300 min<sup>-1</sup>. Engine rating acc. to ECE R120. Fuel tank: 600 l. AdBlue tank: 40 l.

**Transmission:** Main transmission: mechanical ZF AS-Tronic transmission, type 12 AS 2531, with integrated intarder, electro-pneumatically actuated dry clutch and fully automatic transmission control system. 12 forward gears and 2 reverse gears. If necessary, semi-automatic mode (Tip-Tronic) is possible with manual gear selection.

**Transfer case:** Two-stage.

**Drive:** 10 x 6

#### Axles:

1<sup>st</sup> axle: steered, not driven; with differential lock, transverse.

2<sup>nd</sup> axle: steered, driven; with differential lock, transverse.

3<sup>rd</sup> axle: steered, not driven.

4<sup>th</sup> axle: steered, driven; with differential lock, longitudinal and transverse.

5<sup>th</sup> axle: steered, driven; with differential lock, transverse.

**Suspension:** Hydro-pneumatic suspension with levelling adjustment.

**Brake system:** Air-operated dual-circuit disc brake system with electrical wear indicator and air drier. Parking brake: spring loaded type acting on 2<sup>nd</sup>, 4<sup>th</sup> and 5<sup>th</sup> axles. Intarder and engine brake as continuous service brake.

**Tyres:** (10) 445/95 R 25 (16.00 R 25).

**Steering system:** ZF Servocom, dual-circuit hydraulic steering with emergency steering pump. Mechanical steering of 1<sup>st</sup> and 2<sup>nd</sup> axles and automatic steering of the 3<sup>rd</sup> and 4<sup>th</sup> axles up to a travel speed of 25 km/h and of the 5<sup>th</sup> axle up to 50 km/h.

**Carrier cab:** Two man full width cab of composite (steel sheet metal and fibre-glass) structure, with safety glass, central locking system, air-cushioned seats, driver's seat offering various adjustment options, with memory function and heater, engine dependent water heater, air conditioning, Bluetooth hands-free equipment, multifunction display, rear view camera, radio/CD player with USB port, control and operating elements for driving operation, Cruise Control and hill braking feature.

**Electrical system:** 24 Volt DC system, 2 batteries, CAN bus system with integral self-test CSS system, outrigger area lighting. Electrical system conforms with ECE regulations.

#### Optional equipment: (at extra charge)

Towing attachment, autonomous supplementary heating with engine-preheater, drive 10 x 8, ABS system, 525/80 R 25 (20.5 R 25) tyres, spare wheel, special paint and lettering. Further optional equipment available upon request.

### Superstructure

**Frame:** Torsion-resistant welded structure with single-race ball-bearing slewing ring with external gearing, rotating through 360°. Central lubrication system.

**Engine:** Mercedes-Benz 4 cylinder diesel engine, type OM 934 LA (EUROMOT VI / EPA Tier 4f), water-cooled. The engine speed can be varied progressively via a pedal. Engine displacement 5.1 l. Rated at 129 kW (175 HP) at 2200 min<sup>-1</sup>. Torque 750 Nm at 1200 - 1600 min<sup>-1</sup>. Engine rating acc. to ECE R120. Fuel tank: 250 l. AdBlue tank: 19 l.

**Hydraulic system:** Three-circuit diesel-hydraulic system, 1 power-controlled axial piston double pump (electro-hydraulically adjustable), and 1 axial piston pump and 1 gear pump, oil cooler.

**Controls:** Electrically pre-controlled, 2 joy-stick levers.

**Telescopic boom:** 6 sections, made of high tensile fine-grained steel, consisting of 1 base boom and 5 telescoping sections, 1 telescopic cylinder, extendable hydraulically under partial load. 12.8 m to 60.0 m long. Boom head with 6 sheaves.

**Boom elevation:** One differential cylinder with attached lowering brake check valve.

**Main winch:** Axial-piston variable-displacement motor, winch drum with integrated planetary reduction and hydraulically controlled spring-loaded multiple disc brake with integrated free rotation (no sagging of the load when hoisting). Drum rotation indicator. Hoist cable with "Super Stop" easy reeving system.

**Slewing system:** Axial-piston constant-rate motor, three-stage planetary gear with parking brake. Open hydraulic circuit with swing mechanism lock-out. Swing speed steplessly variable from 0 to 1.6 min<sup>-1</sup>.

**Counterweight:** Total 42.4 t, divisible. Controlled from superstructure cab.

**Superstructure cab:** Spacious crane cab of composite steel / plastic design with tempered tinted glass windows, tiltable cockpit with mechanically cushioned adjustable driver's seat with heater, autonomous supplementary heater with engine pre-heating. Air conditioning, radio / CD player, controls and instrumentation for crane operation, outrigger actuation and carrier engine features.

**Electrical system:** 24 V DC system, 2 batteries.

**Safety devices:** 'Lift Adjuster', electronic load moment limiter (LMB) with pilot lamp in several colors, slewing area and working range limitation with 'Slow-Stop' feature, hoist limit switch, lower limit switch, safety valves protect against pipe and hose failures.

#### Optional equipment: (at extra charge)

Jib 1 m + 2.8 m to 1 m + 31 m, offsets 0°, 20° and 40° or hydraulically 0°- 40°, HTLJ jib 1.6 m + 7.4 m to 1.6 m + 17.4 m (hydraulically tiltable and telescopable 5° to 60°), 10 t hook tackle, selection of hook blocks from 32 t to 160 t, 2<sup>nd</sup> winch, supplementary oil cooler, special paint and lettering, supported forces display. Further optional equipment available upon request.

## Unterwagen

**Rahmen:** Verwindungs- und biegesteife Schweißkonstruktion aus hochfestem Feinkornstahl. Zentralschmieranlage.

**Abstützung:** Hydraulische 4-Punkt-Doppelteleskopabstützung inkl. asymmetrischer Abstützbasis und automatischer Längenerkennung, Bedienungsmöglichkeiten an beiden Seiten des Fahrgestelles und in der Oberwagenkabine.  
Abstützbasis 7,5 m (6,2 m / 5,0 m / 4,1 m / 2,5 m) x 8,03 m.

**Motor:** Mercedes-Benz 6-Zylinder-Dieselmotor OM 471 LA (Euromot IV / EPA Tier 4f), wassergekühlt, Hubraum 12,8 l, Leistung 390 kW (530 PS) bei 1700 min<sup>-1</sup>. Drehmoment 2460 Nm bei 1300 min<sup>-1</sup>. Motorleistung nach ECE R120. Kraftstoffbehälter: 600 l. AdBlue-Behälter: 40 l.

**Getriebe:** Hauptgetriebe ZF-AS-Tronic 12 AS 2531, mechanisches Schaltgetriebe mit integriertem Intarder, elektronisch-pneumatisch betätigter Trockenkupplung und vollautomatischer Schaltung mit 12 Vorwärts- und 2 Rückwärtsgängen. Bei Bedarf teilautomatischer Betrieb (Tip-Tronic) mit manueller Gangwahl möglich.

**Verteilergetriebe:** 2-stufiges Verteilergetriebe.

**Antrieb:** 10 x 6

**Achsen:**

1. Achse: gelenkt, nicht angetrieben, Differentialsperre quer.
2. Achse: gelenkt, angetrieben, Differentialsperre quer.
3. Achse: gelenkt, nicht angetrieben.
4. Achse: gelenkt, angetrieben, Differentialsperre längs und quer.
5. Achse: gelenkt, angetrieben, Differentialsperre quer.

**Achsaufhängung:** Hydropneumatische Federung mit Niveauregulierung.

**Bremsen:** Zweikreis-Druckluft-Scheibenbremsanlage mit elektrischer Verschleißanzeige und Lufttrockner. Feststellbremse als Federspeicherbremse an der 2., 4. und 5. Achse wirkend. Intarder und Motorbremse als Dauerbremse.

**Räder:** 10-fach 445/95 R 25 (16.00 R 25).

**Lenkung:** ZF-Servocom-Zweikreishydraulenlenkung mit Notlenkpumpe. Mechanische Lenkung der 1. und 2. Achse und Mittlenken der 3. und 4. Achse bis zu einer Geschwindigkeit von 25 km/h und der 5. Achse bis zu 50 km/h.

**Unterwagenkabine:** Zwei-Mann-Frontfahrerhaus in Stahl-Kunststoff-Verbund-Konstruktion, Sicherheitsverglasung, Zentralverriegelung, luftgefederte Sitze, Fahrersitz vielseitig einstellbar mit Memoryfunktion und beheizbar, motorabhängige Wasserheizung, Klimaanlage, Bluetooth Freisprecheinrichtung, Multifunktionsdisplay, Rückfahrkamera, Radio/CD-Player mit USB Anschluss, Kontroll- und Bedienungselemente für den Fahrbetrieb, Tempomat- / Bremsomat-Funktion.

**Elektrische Anlage:** 24 Volt-Gleichstrom, 2 Batterien, CAN-Bus System mit integriertem CSS-System zur Eigendiagnose, Abstützfeldbeleuchtung. Die elektrische Anlage entspricht der ECE-Richtlinie.

**Zusatzrüstung:** (gegen Mehrpreis)

Anhängekupplung, motorunabhängige Zusatzheizung mit Motorvorwärmung, 10 x 8 Antrieb, ABS, 525/80 R 25 (20.5 R 25) Bereifung, Reserverad, Sonderlackierung und Beschriftung. Weitere Zusatzrüstung auf Anfrage.

## Oberwagen

**Rahmen:** Verwindungssteife Schweißkonstruktion mit einer außenverzahnten, einreihigen Kugeldrehverbindung, um 360° unbegrenzt drehbar. Zentralschmieranlage.

**Motor:** Mercedes-Benz 4-Zylinder-Dieselmotor OM 934 LA (Euromot IV / EPA Tier 4f), wassergekühlt. Drehzahl ist über Fußpedal stufenlos regelbar, Hubraum 5,1 l, Leistung 129 kW (175 PS) bei 2200 min<sup>-1</sup>. Drehmoment 750 Nm bei 1200 - 1600 min<sup>-1</sup>. Motorleistung nach ECE R120. Kraftstoffbehälter: 250 l. AdBlue-Behälter: 19 l.

**Hydraulik System:** Diesel-hydraulisch mit 3-Kreishydraulik, 1 leistungsgeregelte Axialkolbendoppelpumpe (elektrohydraulisch verstellbar), 1 Axialkolbenpumpe und 1 Zahnradschlepppumpe, Ölkühler.

**Steuerung:** Zwei 4-fach Kreuzsteuerhebel mit elektrischer Vorsteuerung.

**Teleskopausleger:** Sechsteiliger Teleskopausleger aus hochfestem Feinkornstahl, bestehend aus einem Grundausleger und 5 Teleskopteilen, 1 Teleskopzylinder, hydraulisch unter Teillast teleskopierbar. 12,8 m - 60,0 m lang. Rollenkopf mit 6 Seilrollen.

**Wippwerk:** Ein Differentialzylinder mit angebautem Senkbremssperrentil.

**Hubwerk:** Axialkolben-Verstell-Motor, Hubwerkstrommel mit eingebautem Planetengetriebe und federbelasteter Hydro-Lamellenbremse mit integriertem Freilauf beim Heben. Seilwindendrehmelder. Hubseil mit 'Super-Stop' Einrichtung.

**Drehwerk:** Axialkolben-Konstant-Motor, dreistufiges Planetengetriebe mit Feststellbremse. Offener Hydraulikkreislauf mit Drehwerk-Freischaltung. Drehgeschwindigkeit stufenlos von 0 - 1,6 min<sup>-1</sup>.

**Gegengewicht:** Gesamtgewicht 42,4 t, teilbar. Die Bedienung erfolgt aus der Oberwagenkabine.

**Oberwagenkabine:** Großräumige Krankabine in Stahl-Kunststoffausführung mit Sicherheitsverglasung und getönten Scheiben, kippbarem Arbeitsplatz mit verstellbarem, mechanisch gedämpftem Fahrersitz mit Heizung, motorunabhängige Zusatzheizung mit Motorvorwärmung, Klimaanlage, Radio / CD-Player, Kontroll- und Bedienungselemente für Kranbetrieb. Betätigung der Abstützung und Motorfunktionen des Unterwagens.

**Elektrische Anlage:** 24 Volt-Gleichstrom, 2 Batterien.

**Sicherheitseinrichtungen:** 'Lift Adjuster', Elektronische Lastmomentbegrenzung (LMB) mit Ampelkennleuchte, Dreh- und Arbeitsbereichsbegrenzung mit 'Slow-Stop' Funktion, Hubendschalter, Windendenschalter, Sicherheitsventile gegen Rohr- und Schlauchbrüche.

**Zusatzrüstung:** (gegen Mehrpreis)

Auslegerverlängerung 1 m + 2,8 m bis 1 m + 31 m, wahlweise abwinkelbar 0°, 20° und 40° oder hydraulisch 0°- 40°, Auslegerverlängerung HTLJ 1,6 m + 7,4 m bis 1,6 m + 17,4 m (hydraulisch abwinkel- und teleskopierbar 5° - 60°), 10 t Hakengeschirr, Unterflaschen von 32 t bis 160 t, 2. Hubwinde, Zusatzölkühler, Sonderlackierung und Beschriftung, Stützkraftanzeige. Weitere Zusatzrüstung auf Anfrage.

# Équipement

## Châssis

**Châssis:** Construction mécano-soudée, en acier à grain fin très rigide, résistant aux flexions et aux torsions. Système de graissage centralisé.

**Calage:** Dispositif de calage horizontal et vertical double en 4 points, entièrement déployable hydrauliquement, y compris distance entre appuis asymétrique et détection de longueur automatique, commande des mouvements sur les deux côtés du porteur et depuis la cabine de la superstructure. Calage 7,5 m (6,2 m / 5,0 m / 4,1 m / 2,5 m) x 8,03 m.

**Moteur:** Mercedes-Benz diesel 6 cylindres, modèle OM 471 LA (Euromot IV / EPA Tier 4f), refroidi à eau, cylindrée 12,8 l, puissance 390 kW (530 CV) à 1700 min<sup>-1</sup>. Couple 2460 Nm à 1300 min<sup>-1</sup>. Puissance moteur selon ECE R120. Capacité du réservoir: 600 l. Capacité du réservoir AdBlue: 40 l.

**Boîte de vitesse:** Boîte principale ZF-AS-Tronic, modèle 12 AS 2531, boîte de vitesses mécanique avec intarder intégré, embrayage à sec électro-pneumatique et commande des vitesses complètement automatique avec 12 vitesses AV et 2 vitesses AR. Si nécessaire, mode partiellement automatique (Tip-Tronic) avec sélection de vitesses manuelle possible.

**Boîte de transfert:** Boîte de transfert à 2 gammes.

**Entraînement:** 10 x 6

### Essieux:

- 1<sup>er</sup> essieu: directeur, non entraîné, blocage de différentiel transversal.
- 2<sup>ème</sup> essieu: directeur, entraîné, blocage de différentiel transversal.
- 3<sup>ème</sup> essieu: directeur, non entraîné.
- 4<sup>ème</sup> essieu: directeur, entraîné, blocage de différentiel longitudinal et transversal.
- 5<sup>ème</sup> essieu: directeur, entraîné, blocage de différentiel transversal.

**Suspension:** Hydro-pneumatique, avec réglage de niveau.

**Freins:** Système de frein à disque, à air comprimé, à double circuit, avec indicateur d'usure électrique et sécheur d'air. Frein de stationnement: avec accumulateurs à ressort agissant sur les essieux 2, 4 et 5. ressorts accumulateurs. Intarder et frein moteur comme frein continu.

**Pneus:** 10 x 445/95 R 25 (16:00 R 25).

**Direction:** Marque ZF Servocom hydraulique à double circuit, avec pompe de secours pour direction Direction mécanique des 1<sup>er</sup> et 2<sup>ème</sup> essieux et direction automatique des 3<sup>ème</sup> et 4<sup>ème</sup> essieux jusqu'à une vitesse de 25 km/h et du 5<sup>ème</sup> essieu jusqu'à 50 km/h.

**Cabine:** Cabine bi-place, construction en matière combinée (acier/matière plastique), vitres en verre de sécurité, système de verrouillage central, sièges à suspension pneumatique, siège du conducteur à plusieurs réglages, avec fonction de mémoire et chauffant, chauffage d'eau alimenté par le moteur, climatiseur, dispositif mains libres Bluetooth, affichage multifonctions, caméra de recul, radio / CD-player avec connecteur USB, éléments de contrôle et de commande pour la conduite, régulateur de vitesse, système automatique de freinage.

**Système électrique:** 24 V courant continu, 2 batteries, système du bus CAN avec système autodiagnostic CSS intégré, éclairage de la distance entre appuis. Conforme à la norme ECE.

**Équipement supplémentaire:** (avec supplément de prix) Attache-remorque, chauffage auxiliaire indépendant du moteur avec préchauffage du moteur, entraînement 10 x 8, système ABS, pneus 525/80 R 25 (20.5 R 25), roue de secours, peinture spéciale et inscription. Autres équipements supplémentaires sur demande.

## Superstructure

**Plate forme:** Construction mécano-soudée résistante à la torsion, couronne d'orientation à billes à une rangée, à denture extérieure, permettant une rotation illimitée sur 360°. Système de graissage centralisé.

**Moteur:** Mercedes-Benz diesel 4 cylindres, modèle OM 934 LA (Euromot IV / EPA Tier 4f), refroidi par eau. Réglage du nombre de tours en continu par pédale, cylindrée 5,1 l, puissance 129 kW (175 CV) à 2200 min<sup>-1</sup>. Couple 750 Nm à 1200 - 1600 min<sup>-1</sup>. Puissance moteur selon ECE R120. Capacité du réservoir: 250 l. Capacité du réservoir AdBlue: 19 l.

**Système hydraulique:** Système diesel-hydraulique à trois circuits, 1 double pompe à piston axial réglée en fonction de la puissance (à réglage électro-hydraulique) 1 pompe à piston axial et 1 pompe à engrenages, radiateur d'huile.

**Commande:** 2 manipulateurs à commande en croix (4 sens), assistés électriquement.

**Flèche télescopique:** Flèche télescopique à six éléments, en acier à texture fine et très résistant, se composant d'une flèche de base et de 5 éléments télescopiques, 1 vérin de télescopage, télescopable hydrauliquement sous charge partielle. Longueur 12,8 m à 60,0 m. Tête de flèche avec 6 poulies.

**Mécanisme de relevage:** Un vérin différentiel pourvu d'une valve d'équilibrage limitant la vitesse de descente.

**Mécanisme de levage:** Moteur à cylindrée variable à piston axial, tambour de levage avec boîte planétaire incorporé et frein d'arrêt à disques multiples hydraulique à ressort, libéré lors du levage. Indicateur de rotation du treuil. Câble de levage avec dispositif "Super-Stop".

**Groupe de rotation:** Moteur à cylindrée constante à pistons axiaux, avec engrenage planétaire de trois étages avec frein d'arrêt. Circuit hydraulique ouvert avec déconnexion du groupe de rotation. Vitesse de rotation réglable progressivement de 0 à 1,6 min<sup>-1</sup>.

**Contrepoids:** Total 42,4 t, divisible. Commande à partir de la cabine de grue.

**Cabine du grutier:** Cabine de grue spacieuse, construction en matière composite acier / synthétique, vitrage de sécurité en verre teinté, place de travail inclinable avec siège du conducteur réglable, amorti mécaniquement, chauffant; chauffage auxiliaire autonome avec préchauffage du moteur, climatiseur, radio / CD-player, éléments de commande et de contrôle pour le service de grue. Actionnement des outriggers et des fonctions du moteur du châssis.

**Système électrique:** 24 V courant continu, 2 batteries.

**Dispositifs de sécurité:** 'Lift Adjuster', contrôleur de l'état de charge (CEC) électronique avec lampe de signalisation, limitation du rayon de rotation et du rayon de travail avec fonction 'Slow-Stop', interrupteur fin de course de levage, interrupteur fin de course de treuil, soupapes de sécurité contre les ruptures de tuyaux et flexibles.

**Équipement supplémentaire:** (avec supplément de prix) Rallonge de flèche 1 m + 2,8 m à 1 m + 31 m au choix inclinable 0°, 20° et 40° ou hydrauliquement 0° à 40°, rallonge de fleche HTLJ 1,6 m + 7,4 m à 1,6 m + 17,4 m (inclinable et télescopable hydrauliquement de 5° à 60°, ensemble des crochets porte-charge de 10 t, mofles de 32 t à 160 t, 2<sup>ème</sup> treuil de levage, radiateur d'huile supplémentaire, peinture spéciale et inscription, affichage des forces d'appui. Autres équipements supplémentaires sur demande.

## Chasis

**Bastidor:** Construcción de acero de alta resistencia soldado, resistente a la torsión y a la flexión. Sistema de engrase central.

**Estabilización:** Estabilizadores telescópicos hidráulicos dobles de 4 puntos, incl. base de apoyo asimétrica y detección automática de longitud, posibilidad de manejo desde ambos lados del chasis portante y desde la cabina de la grúa. Extensión de los estabilizadores: 7,5 m (6,2 m / 5,0 m / 4,1 m / 2,5 m) x 8,03 m.

**Motor:** Mercedes-Benz de 6 cilindros diesel, modelo OM 471 LA (Euromot IV / EPA Tier 4f), refrigerado por agua, cilindrada 12,8 l, potencia: 390 kW (530 CV) a 1.700 min<sup>-1</sup>. Par: 2.460 Nm a 1.300 min<sup>-1</sup>. Potencia del motor según ECE R120. Depósito de combustible: 600 l. Depósito AdBlue: 40 l.

**Transmisión:** Transmisión principal mecánica del tipo ZF-AS-Tronic 12 AS 2531 con intarder integrado, con embrague en seco con accionamiento electro-neumático y cambio automático con 12 marchas delanteras y 2 marchas traseras. Si fuera necesario, se puede operar la transmisión en forma parcialmente automática (Tip-Tronic), seleccionando las marchas manualmente.

**Divisor de fuerza:** Caja de distribución (transfer) con 2 relaciones de velocidad.

**Tracción:** 10 x 6

**Ejes:**

1º eje: de dirección, no accionado, con bloqueo diferencial transversal.

2º eje: de dirección, accionado, con bloqueo diferencial transversal.

3º eje: de dirección, no accionado.

4º eje: de dirección, accionado, con bloqueo diferencial longitudinal y transversal.

5º eje: de dirección, accionado, con bloqueo diferencial transversal.

**Suspensión de los ejes:** Suspensión hidroneumática con regulación de nivel.

**Frenos:** Sistema de frenos de disco neumático de doble circuito con indicador de desgaste eléctrico y secador de aire. Freno de estacionamiento del tipo freno de muelle, accionando en los ejes 2, 4 y 5. Intarder y freno de motor como freno continuo.

**Neumáticos:** 10 x 445/95 R 25 (16.00 R 25).

**Dirección:** Dirección hidráulica ZF Servocom de doble circuito con bomba hidráulica de emergencia. Dirección mecánica al 1º y 2º eje y direccionable al 3º y 4º eje hasta una velocidad de 25 km/h y al 5º eje hasta 50 km/h.

**Cabina del chasis:** Cabina de conductor frontal para dos personas construida en material compuesto de chapa de acero y plástico, acristalamiento de seguridad, bloqueo central, asientos neumáticos, asiento del conductor regulable en múltiples posiciones con función memoria y calefactable, calefacción por agua dependiente del motor, climatizador, dispositivo manos libres con Bluetooth, display multifunción, cámara de marcha atrás, radio/reproductor CD con toma USB, elementos de control y mando para el modo de conducción, regulador de velocidad, sistema automático de frenado.

**Sistema eléctrico:** 24 voltios de corriente continua, 2 baterías, sistema de bus CAN con sistema CSS de autodiagnóstico integrado, iluminación de la zona de apoyo. El sistema eléctrico cumple la normativa ECE.

**Equipamiento adicional:** (con suplemento de precio) Enganche para remolque, calefacción adicional independiente del motor con precalefacción del motor, tracción 10 x 8, sistema antibloqueo ABS, neumáticos 525/80 R 25 (20.5 R 25), rueda de repuesto, pintura especial y rotulación. Otros equipamientos adicionales sobre pedido.

## Superestructura

**Bastidor:** Construida en acero soldado, resistente a la torsión, corona de giro con rodamiento de una fila de bolas con dientes externos con giro continuo de 360°. Sistema de engrase central.

**Motor:** Mercedes-Benz de 4 cilindros diesel, modelo OM 934 LA (Euromot IV / EPA Tier 4f), refrigerado por agua. Las revoluciones aumentan de forma gradual accionando el acelerador, cilindrada 5,1 l, potencia: 129 kW (175 CV) a 2.200 min<sup>-1</sup>. Par: 750 Nm a 1.200 - 1.600 min<sup>-1</sup>. Potencia del motor según ECE R120. Depósito de combustible: 250 l. Depósito AdBlue: 19 l.

**Sistema hidráulico:** Sistema dieselhidráulico de 3 circuitos, 1 bomba doble de pistones axiales con regulación de caudal (regulable electro-hidráulicamente), 1 bomba de pistones axiales y 1 bomba de engranajes, radiador de aceite.

**Controles:** 2 palancas de control de tipo joy-stick para movimientos simultáneos de la grúa (4 direcciones), asistidas eléctricamente.

**Pluma telescópica:** Pluma telescópica de seis secciones de acero de alta resistencia soldado; se compone de un tramo base y 5 tramos telescópicos, 1 cilindro telescópico; los tramos pueden telescoparse hidráulicamente bajo carga parcial. Longitud de 12,8 m a 60,0 m. Cabeza de pluma con 6 poleas.

**Mecanismo de basculado:** Mediante un cilindro diferencial con válvula de retención de bajada de bloqueo integrada.

**Cabrestante principal:** Motor de cilindrada variable de pistones axiales, tambor del cabrestante con reducción planetaria incorporada y freno de discos múltiples cargado por resorte con sistema libre de elevación. Indicador de giros del cabrestante. Cable de elevación con sistema "Super-Stop".

**Sistema de giro:** Motor de cilindrada constante de pistones axiales, reducción planetaria de tres etapas con freno de estacionamiento. Circuito hidráulico abierto con desbloqueo del mecanismo giratorio. Velocidad de giro variable continuamente de 0 a 1,6 min<sup>-1</sup>.

**Contrapeso:** Peso total: 42,4 t, divisible. Se acciona desde la cabina de la superestructura.

**Cabina de la grúa:** Cabina de grúa espaciosa en construcción de acero y plástico, cristales tintados de seguridad, puesto de trabajo inclinable con asiento de conductor regulable, amortiguado mecánicamente y calefactable, calefacción adicional independiente del motor con precalefacción del motor, climatizador, radio / reproductor de CD, elementos de control y mando para el manejo de la grúa. Accionamiento de estabilizadores y funciones chasis-motor.

**Sistema eléctrico:** 24 voltios de corriente continua, 2 baterías.

**Dispositivos de seguridad:** "Lift Adjuster", limitador electrónico del momento de carga (LMC) con luz de señalización tipo semáforo, limitación de la zona de giro y del área de trabajo con función "Slow-Stop", interruptor de fin de carrera de elevación, interruptor de fin de carrera del cabrestante, válvulas de seguridad contra roturas de tubos y latiguillos.

**Equipamiento adicional:** (con suplemento de precio) Plumín de 1 m + 2,8 m a 1 m + 31 m, regulable opcionalmente de 0°, 20° y 40° (o hidráulicamente 0° a 40°), alargamiento de pluma HTLJ de 1,6 m + 7,4 m a 1,6 m + 17,4 m (telescopable y regulable hidráulicamente de 5° a 60°), accesorios de gancho de 10 t, pastecas de carga de 32 t a 160 t, 2º cabrestante, radiador de aceite adicional, pintura especial y rotulación, indicador de la fuerza de apoyo. Otros equipamientos adicionales sobre pedido.

## Equipaggiamento

### Carro

**Telaio:** Struttura saldata resistente a sollecitazioni a torsione e flessione in acciaio a grano fine ad alta resistenza. Impianto di lubrificazione centrale.

**Stabilizzazione:** Stabilizzazione telescopica doppia su 4 punti, di tipo idraulico, incl. base di appoggio asimmetrica, rilevamento automatico lunghezza, possibilità di comando dai due lati del telaio e dalla cabina della sovrastruttura. Base di appoggio 7,5 m (6,2 m / 5,0 m / 4,1 m / 2,5 m) x 8,03 m.

**Motore:** Motore Diesel a 6 cilindri Mercedes-Benz OM 471 LA, (Euromot IV / EPA Tier 4f), raffreddato ad acqua, cilindrata 12,8 l, potenza 390 kW (530 PS) a 1700 min<sup>-1</sup>. Coppia 2460 Nm a 1300 min<sup>-1</sup>. Potenza motore conforme a ECE R120. Serbatoio carburante: 600 l. Serbatoio AdBlue: 40 l.

**Cambio:** Trasmissione principale cambio meccanico ZF-AS-Tronic 12 AS 2531 con Intarder integrato, frizione a secco ad azionamento elettro-pneumatico e innesto marce automatico, con 12 marce avanti e 2 retromarce. Opzionale: funzionamento parzialmente automatico (Tiptronic) con selezione marce manuale.

**Gruppo di rinvio:** Gruppo di rinvio a 2 stadi.

**Trasmissione:** 10 x 6

#### Assi:

- 1° asse: snodato, non asse motore, bloccaggio differenziale trasversale.
- 2° asse: snodato, asse motore, bloccaggio differenziale trasversale.
- 3° asse: snodato, non asse motore.
- 4° asse: snodato, asse motore, bloccaggio differenziale longitudinale e trasversale.
- 5° asse: snodato, asse motore, bloccaggio differenziale trasversale.

**Sospensione assiale:** Sospensione idro-pneumatica con regolazione di livello.

**Freni:** Impianto ad aria compressa per freno a doppio circuito e a disco con indicazione usura elettronica ed essiccatore di aria. Freno di stazionamento con funzione di freno a molla a rilascio pneumatico sul 2°, 4° e 5° asse. Intarder e freno motore come freno continuo.

**Ruote:** 10x 445/95 R 25 (16.00 R 25).

**Sterzo:** Sistema idroguida a doppio circuito ZF Servocom con pompa sterzo di emergenza. Sterzata meccanica del 1° e 2° asse e attivazione sul 3° e 4° asse fino a una velocità di 25 km/h e sul 5° asse fino a 50 km/h.

**Cabina del carro:** Cabina conducente frontale per due in struttura composita acciaio-plastica, vetratura di sicurezza, chiusura centralizzata, sedili molleggiati, sedile conducente impostabile in vari modi con funzione memory e riscaldamento, riscaldamento acqua dipendente dal motore, climatizzatore, vivavoce Bluetooth, display multifunzione, telecamera retromarcia, radio/lettore CD con collegamento USB, elementi di controllo e comando per la marcia e funzioni Tempomat e Bremsomat.

**Impianto elettrico:** Corrente continua 24 Volt, 2 batterie, sistema CANBus con sistema CSS integrato per autodiagnosi, illuminazione zona di stabilizzazione. L'impianto elettrico è conforme alle norme ECE.

**Equipaggiamento aggiuntivo:** (a sovrapprezzo)

Gancio di traino, riscaldamento supplementare indipendente dal motore con preriscaldamento motore, trasmissione 10 x 8, ABS, pneumatici 525/80 R 25 (20.5 R 25), ruota di scorta, verniciatura speciale e diciture. Altro equipaggiamento aggiuntivo su richiesta.

### Sovrastruttura

**Telaio:** Struttura saldata resistente alla torsione con corona di rotazione a sfere ad una fila, dentata esternamente, ruotabile di 360° senza limitazioni. Impianto di lubrificazione centrale.

**Motore:** Motore Diesel a 4 cilindri Mercedes-Benz OM 934 LA, (Euromot IV / EPA Tier 4f), raffreddato ad acqua. Regolazione continua numero di giri da pedale, cilindrata 5,1 l, potenza 129 kW (175 PS) a 2200 min<sup>-1</sup>. Coppia 750 Nm a 1200 - 1600 min<sup>-1</sup>. Potenza motore conforme a ECE R120. Serbatoio carburante: 250 l. Serbatoio AdBlue: 19 l.

**Impianto idraulico:** Diesel-idraulico con idraulica a 3 circuiti, 1 pompa doppia a pistoni assiali con regolazione di potenza (regolazione elettroidraulica), 1 pompa a pistoni assiali e 1 pompa a ingranaggi, radiatore olio.

**Comando:** Due leve di comando gru x4 con precomando elettrico.

**Braccio telescopico:** Braccio telescopico in sei sezioni in acciaio a grano fine ad alta resistenza, composto da un braccio base e 5 sezioni telescopiche, 1 cilindro telescopico, funzione telescopica ad azionamento idraulico sotto carico parziale. Lunghezza 12,8 m - 60,0 m. Testa rullo con 6 pulegge.

**Gruppo di brandeggio:** Un cilindro differenziale con valvola di non ritorno freno integrata.

**Meccanismo di sollevamento:** Servomotore a pistone assiale, tamburo del meccanismo di sollevamento con rotismo epicicloidale incorporato e freno a disco idraulico sollecitato a molla con ruota libera integrata nel sollevamento. Indicatore delle rotazioni dei verricelli. Fune di sollevamento con dispositivo 'Super-Stop'.

**Gruppo di rotazione:** Motore costante a pistoni assiali, ingranaggio epicicloidale a tre stadi con freno di stazionamento. Circuito idraulico aperto con attivazione gruppo di rotazione. Velocità di rotazione regolabile in continuo da 0 a 1,6 min<sup>-1</sup>.

**Contrappeso:** Peso complessivo 42,4 t, divisibile. L'azionamento si effettua dalla cabina della sovrastruttura.

**Cabina della sovrastruttura:** Spaziosa cabina della gru in acciaio-plastica con vetratura di sicurezza e cristalli oscurati, postazione di lavoro ribaltabile con sedile conducente regolabile, con molleggio meccanico e riscaldamento, riscaldamento supplementare indipendente dal motore con preriscaldamento motore, climatizzatore, radio/lettore CD, elementi di controllo e comando per esercizio gru. Azionamento della stabilizzazione e funzioni motore del carro.

**Impianto elettrico:** Corrente continua 24 Volt, 2 batterie.

**Dispositivi di sicurezza:** 'Lift Adjuster', limitatore del momento di carico (LMC) elettronico con luce di riferimento a semaforo, delimitazione dell'area di rotazione e delimitazione dell'area di lavoro con funzione Slow-Stop, interruttore di fine corsa, fine corsa argani, valvole di sicurezza contro rottura tubi e tubi flessibili.

**Equipaggiamento aggiuntivo:** (a sovrapprezzo)

Prolunga del braccio 1 m + 2,8 m a 1 m + 31 m a scelta con regolazione angolo 0°, 20° e 40° o regolazione idraulica 0° - 40°, prolunga del braccio HTLJ da 1,6 m + 7,4 m a 1,6 m + 17,4 m (a regolazione idraulica e telescopica 5° - 60°), gancio da 10 t, bozzelli da 32 t a 160 t, secondo argano di sollevamento, radiatore olio supplementare, verniciatura speciale e diciture, indicazione della capacità di appoggio. Altro equipaggiamento aggiuntivo su richiesta.



## Ходовая платформа

**Рама:** Жёсткая на скручивание и изгиб сварная конструкция из высокопрочной мелкозернистой стали. Централизованная смазочная система.

**Аутригеры:** Гидравлическая опора в четырех точках, включая поддержку асимметричной базы аутригеров и автоматическое распознавание положения стрелы, возможность управления с обеих сторон ходовой части и из кабины на поворотной платформе.  
Опорная база 7,5 м (6,2 м / 5,0 м / 4,1 м / 2,5 м) x 8,03 м.

**Двигатель:** 6-цилиндровый дизельный двигатель Mercedes-Benz OM 471 LA, (Euromot IV / EPA Tier 4f), с водяным охлаждением. Рабочий объем двигателя 12,8 л, мощность 390 кВт (530 л.с.) при 1 700 об/мин. Крутящий момент 2 460 Н·м при 1 300 об/мин. Мощность двигателя согласно ECE R120. Топливный бак: 600 л. Бак для присадки AdBlue: 40 л.

**Коробка передач:** Главный редуктор ZF-AS-Tronic 12 AS 2531 со встроенным интардером, электронно-пневматическим управлением сухим дисковым сцеплением и полностью автоматическим переключением 12 передач переднего и 2 передач заднего хода. При необходимости возможен полуавтоматический режим (Tip-Tronic) с переключением передач вручную.

**Раздаточная коробка:** 2-ступенчатая раздаточная коробка.

**Привод:** 10 x 6

**Оси:**

- 1-я ось: управляемая, неприводная, с поперечной блокировкой межколёсного дифференциала.
- 2-я ось: управляемая, приводная, с поперечной блокировкой межколёсного дифференциала.
- 3-я ось: управляемая, неприводная.
- 4-я ось: управляемая, приводная, с продольной и поперечной блокировкой межколёсного дифференциала.
- 5-я ось: управляемая, приводная, с поперечной блокировкой межколёсного дифференциала.

**Подвеска оси:** Гидропневматическая подвеска с регулировкой уровня.

**Тормоза:** Пневматическая двухмагистральная дисковая тормозная система с электронным индикатором износа и осушителем воздуха. Стояночный тормоз, представляющий собой тормозной механизм с пружинным энергоаккумулятором, воздействует на 2-ю, 4-ю и 5-ю оси. Интардер и моторный тормоз в качестве постоянного тормоза.

**Колеса:** 10-ные 445/95 R 25 (16.00 R 25).

**Рулевое управление:** Двухконтурное гидравлическое рулевое управление ZF-Servocom с резервным насосом рулевого управления. Механическое рулевое управление 1-й и 2-й осями и автоматическое подруливание 3-й и 4-й осью при скорости до 25 км/ч и 5-й осью – до 50 км/ч.

**Кабина ходовой платформы:** Двухместная передняя кабина водителя композитной конструкции (металлический лист и стекловолокно), безосколочное стекло, центральный замок, сиденья с пневматической подвеской, сиденье водителя регулируемое по многим параметрам, с функцией памяти и подогревом), водяной отопитель, зависящий от работы двигателя, кондиционер, спикерфон с функцией Bluetooth, многофункциональный дисплей, камера заднего вида, радиоприемник / CD-плеер с портом USB, элементы управления и индикации для ходового режима, функция темпомата / автоматического торможения.

**Система электрооборудования:** 24 вольт пост. тока, 2 аккумуляторные батареи, система шины CAN со встроенной системой CSS для самодиагностики, подсветка аутригеров. Электрооборудование отвечает стандарту ECE.

**Дополнительное оборудование:** (за надбавку к цене) Тягово-сцепное устройство, независимый от работы двигателя дополнительный отопитель с подогревом двигателя, привод 10 x 8, ABS, шины 525/80 R 25 (20.5 R 25), запасное колесо, специальное лаковое покрытие и нанесение надписей. Другое дополнительное оборудование – по запросу.

## Оборудование

### Поворотная платформа

**Рама:** Жёсткая на скручивание сварная конструкция с однорядным сферическим поворотным соединением с внешними зубьями, с неограниченным поворотом на 360°. Централизованная смазочная система.

**Двигатель:** 4-цилиндровый дизельный двигатель Mercedes-Benz OM 934 LA, (Euromot IV / EPA Tier 4f), с водяным охлаждением. Бесступенчатая регулировка оборотов посредством педали. Рабочий объем двигателя 5,1 л, мощность 129 кВт (175 л.с.) при 2 200 об/мин. Крутящий момент 750 Н·м при 1 200–1 600 об/мин. Мощность двигателя согласно ECE R120. Топливный бак: 250 л. Бак для присадки AdBlue: 19 л.

**Гидравлическая система:** Дизельно-гидравлическая с 3-контурным гидроагрегатом, 1 аксиально-поршневой насос двойного действия (с электрогидравлической регулировкой), 1 аксиально-поршневой насос одинарного действия и 1 шестеренный насос, масляный радиатор.

**Система управления:** Два 4-сторонних крестовых рычага управления с предварительным электрическим регулированием.

**Телескопическая стрела:** Шестисекционная телескопическая стрела из высокопрочной мелкозернистой стали, включает основную секцию стрелы и 5 телескопических секций, 1 телескопический цилиндр, выдвигается гидравлическим способом по мере создания нагрузки. Длина 12,8 м – 60,0 м. Роликовая обойма с 6-ю канатными шкивами.

**Механизм изменения подъема стрелы:** Дифференциальный цилиндр со смонтированным на нем запорным клапаном спускного тормоза.

**Подъемный механизм:** Аксиально-поршневой двигатель с переменным рабочим объемом, барабан подъемного механизма с встроенным планетарным редуктором и пружинным гидравлическим многодисковым тормозом с встроенным механизмом свободного хода при подъеме. Сигнализатор вращения барабана лебедки. Подъемный трос с тормозным приспособлением 'Super-Stop'.

**Поворотный механизм:** Аксиально-поршневой двигатель с постоянным рабочим объемом, трехступенчатый планетарный редуктор со стояночным тормозом. Гидравлический контур, работающий по разомкнутой схеме, со схемой включения поворотного механизма. Бесступенчатое изменение скорости вращения, 0 – 1,6 об/мин.

**Противовес:** Общий вес 42,4 т, составной. Управление осуществляется из кабины на поворотной платформе.

**Кабина на поворотной платформе:** Просторная кабина крана композитной конструкции (металл и пластик), остекление тонированным безосколочным стеклом, откидное рабочее место с регулируемым по высоте сиденьем водителя с механическим амортизатором и подогревом, независимый от работы двигателя дополнительный отопитель с подогревом двигателя, кондиционер, радио / CD-плеер, элементы управления и индикации для режима работы крана. Управление выдвиганием ау-триггеров и перемещением крана по рабочей площадке.

**Система электрооборудования:** 24 вольт пост. тока, 2 аккумуляторные батареи.

**Устройства безопасности:** Регулятор подъема 'Lift Adjuster', электронный ограничитель момента нагрузки (LMB) с подачей опознавательных световых сигналов, ограничитель зоны поворота и рабочей зоны с функцией медленной остановки 'Slow-Stop', концевой выключатель лебедки, клапаны безопасности на случай повреждения гидравлических трубок и шлангов.

**Дополнительное оборудование:** (за надбавку к цене) удлинение стрелы 1 м + 2,8 м до 1 м + 31 м, по выбору регулятор угла поворота 0°, 20° и 40° или гидравлический регулятор 0°–40°, удлинитель стрелы HTLJ от 1,6 м + 7,4 м до 1,6 м + 17,4 м (гидравлическое изменение угла и телескопирование 5° - 60°), крюковая подвеска 10 т, крюковые обоймы от 32 т до 160 т, 2-я подъемная лебедка, дополнительный масляный радиатор, специальное лаковое покрытие и нанесение надписей, индикатор опорного усилия Другое дополнительное оборудование – по запросу.

# ADDITIONAL INFORMATION

ZUSATZINFORMATIONEN  
INFORMATIONS SUPPLÉMENTAIRES  
INFORMACIÓN ADICIONAL  
ALTRE INFORMAZIONI  
ДОПОЛНИТЕЛЬНАЯ ИНФОРМАЦИЯ



## Additional information · Zusatzinformationen · Informations supplémentaires

### Remarks relating to the capacity charts · Anmerkungen zu den Traglasttabellen Remarques relatives aux tableaux des charges

1. The lifting capacities in the structural area are based on EN 13000.
2. The lifting capacities in the stability area are based on ISO 4305 / EN 13000.
3. Depending on the boom length, max. wind speeds between 7 m/s and 15 m/s are permissible in the lifting capacity charts.
4. Due to different extending sequences of the telescopes, the boom lengths indicated in the lifting capacity charts may deviate slightly.
5. The lifting capacities are shown in metric tons.
6. The weight of load handling devices such as hook blocks, slings, etc., must be considered as part of the load and must be deducted from the lifting capacities.
7. The lifting capacities for the telescopic boom apply to a crane with no jib being stowed or mounted on the crane.
8. The load radius is the horizontal distance from the centre of the slewing ring to the centre of gravity of a suspended, non-oscillating load.

1. Die Tragfähigkeiten im Festigkeitsbereich basieren auf EN 13000.
2. Die Tragfähigkeiten im Standsicherheitsbereich entsprechen ISO 4305 / EN 13000.
3. In Abhängigkeit der Auslegerlänge sind bei den Traglasttabellen max. Windgeschwindigkeiten zwischen 7 m/s und 15 m/s zulässig.
4. Aufgrund unterschiedlicher Ausfahrfolgen der Teleskope können die in den Traglasttabellen angegebenen Auslegerlängen geringfügig abweichend sein.
5. Die Tragfähigkeiten sind in metrischen Tonnen angegeben.
6. Das Gewicht des Lasthakens bzw. der Unterflasche und weiterer Anschlagmittel ist von der Tragfähigkeit abzuziehen.
7. Die Tragfähigkeiten für den Teleskopausleger gelten nur bei demontierter Auslegerverlängerung.
8. Die Ausladung ist der horizontale Abstand von Mitte Drehkranz bis zum Schwerpunkt freihängender, nicht schwingender Last.

1. Les forces de levage sont conformes aux normes EN 13000.
2. Les forces de levage dans la partie de stabilité au renversement sont conformes aux normes ISO 4305 / EN 13000.
3. Des vitesses de vent max. entre 7 et 15 m/s sont autorisées pour les tableaux des charges en fonction de la longueur de la flèche.
4. Les longueurs de flèche indiquées dans les tableaux des charges peuvent être légèrement divergentes en raison des différentes séries de déploiement des télescopes.
5. Les forces de levage sont données en tonnes métriques.
6. Le poids du crochet-moufle et de tous les accessoires d'élingage font partie de la charge et sont à déduire des charges indiquées.
7. Les forces de levage indiquées pour la flèche télescopique s'entendent rallonge de flèche déposée.
8. La portée est la distance horizontale du milieu de la couronne d'orientation au centre de gravité de la charge suspendue librement sans osciller.

### General remarks · Allgemeine Anmerkungen · Remarques générales

Unless otherwise specified, all the information given in this brochure refers to the standard equipment of the crane and only is intended as general information. For correct crane operation, the original operating manual and lifting capacity charts are essential. No liability is accepted for the accuracy of this information. Errors and omissions excepted. Illustrations are similar only. All dimensions - unless otherwise specified - in mm.

Alle Angaben in dieser Broschüre beziehen sich - wenn nicht anderweitig aufgeführt - auf die Standard-Ausstattung des Krans und dienen nur zur allgemeinen Information. Zum ordnungsgemäßen Betrieb des Krans sind die original Bedienungsanleitung und Traglasttabellen maßgeblich. Alle Angaben erfolgen ohne Gewähr. Änderungen und Irrtümer vorbehalten. Abbildungen ähnlich. Alle Bemaßungen - wenn nicht anders angegeben - in mm.

Sauf indication contraire, toutes les informations dans cette brochure se rapportent à l'équipement standard de la grue et constituent uniquement des informations générales. Pour le fonctionnement correct de la grue, le manuel d'instructions original et les tableaux des charges de levage sont déterminants. Toutes les informations sont fournies sans garantie. Sous réserve de modifications techniques et d'erreurs. Illustrations similaires mais pas identiques à l'engin montré. Toutes les cotes - sauf indication différente - en mm.

### Notas relativas a los gráficos de carga · Annotazioni sulle tabelle delle portate Примечания к таблицам грузоподъемности

1. En cuanto a los datos referentes a resistencia, las capacidades de carga están basados sobre las normas EN 13000.
2. En cuanto a los datos referentes a estabilidad anti-vuelco, las capacidades de carga están basados sobre las normas ISO 4305 / EN 13000.
3. En función de la longitud de la pluma, son admisibles velocidades máx. del viento entre 7 m/s y 15 m/s en las tablas de cargas.
4. Debido a las diferentes secuencias de extensión de los telescopios, es posible que las longitudes de la pluma indicadas en las tablas de cargas sean ligeramente distintas.
5. Las capacidades de carga indicadas en las tablas corresponden a toneladas métricas.
6. Hay que deducir los pesos del gancho, eslingas y de otros dispositivos para fijación de cargas de los valores indicados en las tablas.
7. Las capacidades de carga referentes a la pluma telescópica valen solamente si el alargamiento de pluma está desmontado.
8. El alcance de pluma es la distancia horizontal del centro de la corona de giro al centro de gravedad de una carga suspendida que no está oscilando.

1. Le capacità di carico nel range di resistenza sono riferite alla norma EN 13000.
2. Le capacità di carico nel range di stabilità sono conformi alle norme ISO 4305 / EN 13000.
3. Nelle tabelle delle portate sono ammesse velocità del vento comprese tra 7 m/s e 15 m/s in funzione della lunghezza del braccio.
4. Considerata le diverse sequenze di sfilo dei telescopi, le lunghezze del braccio indicate nelle tabelle delle portate possono essere lievemente differenti.
5. Le capacità di carico sono indicate in tonnellate metriche.
6. Il peso del gancio di carico, ovvero del bozzello e delle altre imbracature deve essere detratto dalla capacità di carico.
7. Le capacità di carico per il braccio telescopico sono applicabili soltanto con prolunga del braccio smontata.
8. Per sbraccio si intende la distanza orizzontale dal centro della corona rotante al centro del carico sospeso, ma non oscillante.

1. Значения грузоподъемности в пределах категории прочности основаны на положениях стандарта EN 13000.
2. Значения грузоподъемности в пределах области устойчивости соответствуют стандарту ISO 4305 / EN 13000.
3. В зависимости от длины стрелы таблицы грузоподъемности допускают скорость ветра от 7 до 15 м/с.
4. Длина телескопической стрелы в выдвинутом состоянии может незначительно отличаться от указанной в таблицах грузоподъемности из-за различных последовательностей выдвигания.
5. Грузоподъемность указана в метрических тоннах.
6. Из грузоподъемности необходимо вычесть вес грузового крюка или крюковой обоймы, а также других грузозахватных приспособлений.
7. Значения грузоподъемности для телескопической стрелы действительны только при демонтированном удлинителе стрелы (гуське).
8. Вылет — это расстояние по горизонтали между центром поворотного круга и центром тяжести свободно подвешенного некачающегося груза.











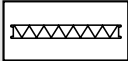

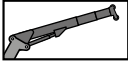
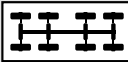















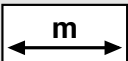

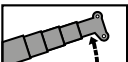
### Notas adicionales · Annotazioni generali · Общие примечания

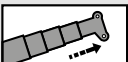
A no ser que se indique lo contrario, todos los datos incluidos en este folleto hacen referencia al equipamiento estándar de la grúa y sólo tienen un carácter informativo general. El manual de instrucciones original y las tablas de capacidades de carga son determinantes para lograr un correcto funcionamiento de la grúa. Todos los datos se facilitan sin garantía. Reservadas las modificaciones y los errores. Ilustraciones similares. Todas las dimensiones - salvo indicación en contrario - en mm.

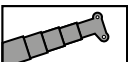
Se non diversamente specificato, tutti i dati di questa brochure si riferiscono alla dotazione standard della gru e sono da considerarsi come informazioni generali. Per un esercizio corretto della gru, sono determinanti il manuale d'uso originale e le tabelle delle portate. Si declina ogni responsabilità per tutti i dati. Con riserva di modifiche ed errori. Figure simili. Tutte le quotature sono in mm (se non diversamente specificato).

Все данные, приведенные в этой брошюре, относятся — если не указано иное — к стандартному оснащению крана и служат лишь для общей информации. Порядок надлежащей эксплуатации крана определяется оригиналом руководства по эксплуатации и таблицами грузоподъемности. Все данные приведены без обязательств. Возможны изменения и ошибки. Иллюстрации являются приблизительными. Все размеры — если не указано другое — в мм.

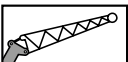
Symbols · Symbolerklärung · Glossaire des symboles  
 Glosario de simbolos · Spiegazione dei simboli · Условные обозначения

	Gross weight · Gesamtgewicht Poids total · Peso total Peso totale · Полная масса		Fly jib section · Spitzenteil Élément de fléchette · Plumín Parte punta · Головная секция
	Axle load · Achslast Charge à l'essieu · Carga por eje Carico assiale · Осьевая нагрузка		Hydraulic telescopic and luffing jib HTLJ · Hydraulische Teleskop- und Wippspitze HTLJ · Fléchette télescopique relevable hydrauliquement HTLJ · Plumín hidráulicamente telescópico y regulable HTLJ Punta oscilante e telescópica idraulica HTLJ · Телескопическая секция и оголовок с гидравлическим приводом HTLJ
	Drive · Antrieb Entraînement · Tracción Trazione · Привод		Swing area · Drehbereich Rayon de rotation · Zona de giro Area di rotazione · Область поворота
	Tyres · Bereifung Pneus · Neumáticos Pneumatici · Шины		Hydraulically lockable · Hydraulisch verriegelbar Verrouillable hydrauliquement · Con embulonamiento hidráulico · Con dispositivo di bloccaggio idraulico Гидравлическая блокировка
	Gradeability · Steigfähigkeit · Capacité de gravisement de pente · Superación de pendientes · Capacità di salita Способность преодолевать подъем		Main winch · Hubwinde · Mécanisme de levage Cabrestante principal · Meccanismo di sollevamento Главная лебедка
	Off road / On road · Gelände / Straße Tout-terrain / Mode "Route" · Todo terreno / En carretera Fuori strada / Su strada · Бездорожье / Дорога		Auxiliary winch · Zusatzhubwinde Treuil supplémentaire · Cabrestante auxiliar Argano aggiuntivo · Дополнительная лебедка
	Speed · Geschwindigkeit Vitesse · Velocidad Velocità · Скорость		Type · Typ Tipo · Тип
	Outriggers · Abstützung Calage · Estabilizadores Stabilizzazione · На аутригерах		Lifting capacity · Traglast Charge de levage · Carga Portata · Грузоподъемность
	Counterweight · Gegengewicht Contrepoids · Contrapeso Contrappeso · Противовес		Rope sheaves · Seilrollen Poulies de câbles · Poleas de cable Pulegge · Канатные шкивы
	Counterweight element · Gegengewichtselement Élément de contrepoids · Parte del contrapeso Parte contrappeso · Деталь противовеса		Parts of line · Seilstränge Brins de câble · Ramales de cable Spiire della fune · Запасовка
	Length · Länge Longueur · Longitud Lunghezza · Длина		Dead-weight · Eigengewicht Poids total · Tara Peso proprio · Собственный вес
	Boom elevation · Wippwerk · Mécanisme de relevage Elevación de pluma · Gruppo di brandeggio Механизм изменения подъема стрелы		Wire rope length · Hubseillänge Longueur du câble de levage · Longitud del cable de izaje · Lunghezza fune di sollevamento Длина подъемного троса
	Boom telescoping · Teleskopieren Télescopage de flèche · Telescopaje de pluma Telescopaggio · Телескопирование		Wire rope diameter · Hubseildurchmesser Diamètre du câble de levage · Diámetro del cable de elevación · Diametro fune di sollevamento Диаметр подъемного троса
	Telescopic boom · Teleskopausleger Flèche télescopique · Pluma telescópica Braccio telescopico · Телескопическая стрела		Wire rope pulling force · Hubseilzugkraft Force de traction du câble de levage · Fuerza de tracción del cable de elevación · Forza di trazione fune di sollevamento · Тяговое усилие подъемного троса
	Radius · Ausladung Portée · Radio Sbraccio · Вылет		Weight · Gewicht Poids · Peso Peso · Bec
	Tilttable jib · abwinkelbare Spitze Fléchette inclinable · Plumín regulable Punta con regolazione angolo Гусек с изменением угла наклона		
	Hydraulically tilttable jib · hydraulisch abwinkelbare Spitze Fléchette inclinable hydrauliquement · Plumín regulable hidráulicamente · Punta con regolazione angolo idraulica Гусек гидравлический с изменением угла наклона		

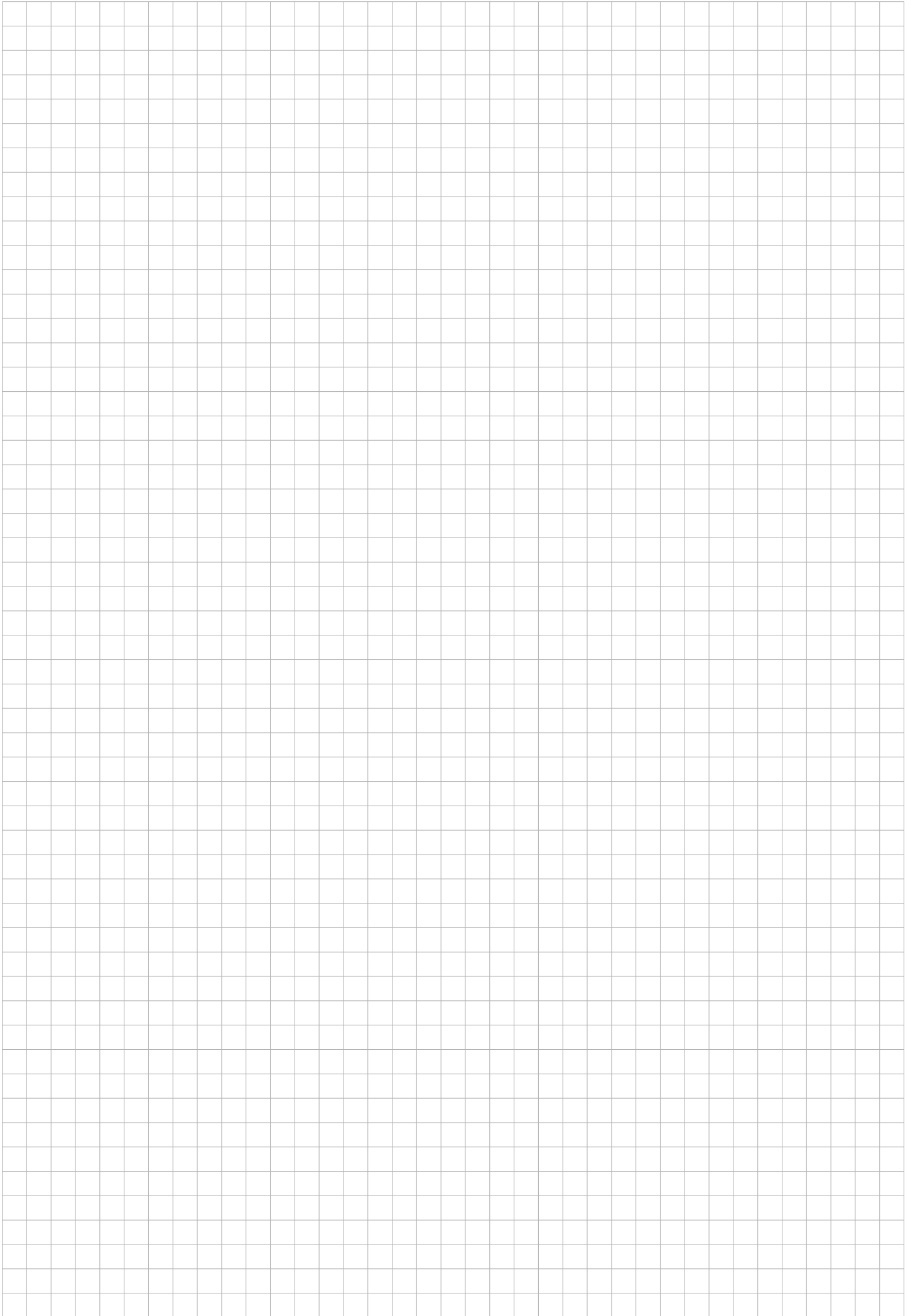



You can find your **direct TADANO contact person** on:  
[www.tadano.com/wwnetwork/](http://www.tadano.com/wwnetwork/)



**TADANO FAUN GmbH**

Faunberg 2 · 91207 Lauf a. d. Pegnitz · Germany  
Phone: +49-9123-185-0 · Fax: +49-9123-3085  
[www.tadanofaun.de](http://www.tadanofaun.de) · [info@tadanofaun.de](mailto:info@tadanofaun.de)

**TADANO LTD.** (International Division)

4-12, Kamezawa 2-chome, Sumida-ku Tokyo 130-0014, Japan  
Phone: 81-3-3621-7750 · Fax: 81-3-3621-7785  
[www.tadano.com](http://www.tadano.com) · [info@tadano.com](mailto:info@tadano.com)