

Model	Fdp	Engine
AD410T48W OFF HR	SV88	C13

The gearbox represented in this drawing is a TX-16M. For other gearbox models please refer to specific drawing 5802770818 DB.

This drawing complies with the standard vehicle configuration. Design and technical drawing are subjected to changes.

All proprietary rights reserved by CNH Industrial N.V. and/or one of its subsidiaries. This drawing shall not be reproduced, or in any way utilized, for the manufacture of the component or unit herein illustrated and must not be released to other parties, without written consent of the proprietor. Any infringement will be legally pursued.

STANDARDS mentioned:
General rules Iveco Std.
10-2999

weights and dimensions on sheet 2

Scale: 1:20		Material	Standards	Code No
CNH0 n° 0		Mass (kg): 0.000	Blank-No	
n° 0		Designation	Lexicon Code	143320
HEAVY TRUCK TECHNICAL DRAWING				
AD410T48W 8x8 T-Way OFF MY2019 E5 WB: 5020/1400				
Name: Marra Date: 30.09.2021 Checked by: Marra Date: 30.09.2021 Approved: Martinez, Ana Department: E040		Index: A0 Modification Notice Code: 11H7T20007040 Date: 09.21 Name: JM		
IVECO T-WAY AD				No: 5803039175 DB 55-9520 Sheet: 1/2 A1
Origin:	Replaces:	Replaced by:		

View B
Attachment steering
and air-intake

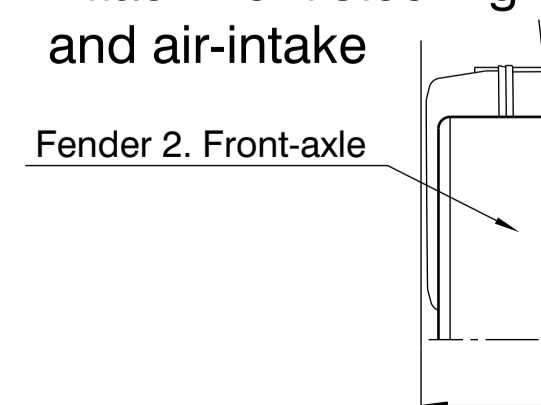

View A

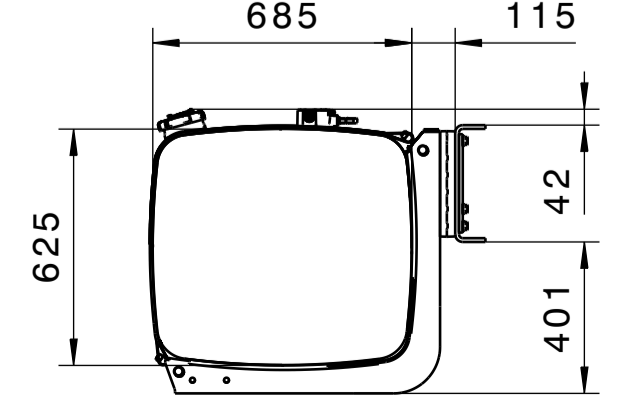

AD410T48W OFF HR				Fdp:SV88			Opt. Gearboxes: ...T48 *ZF16TX2240; ZF16S2520				Eng: C13	
Cabin model	* kerb weight calculated (kg)			maximum admissible gross vehicle weight (kg)			G (mm)		M (kg)	remark		
	total	front axle	rear axle	total max.	front axle max.	rear axle max.	min	max				
AD-HR-TP	12198	7935	4263	41000	16000	26000	1175	1330	28802	standard		
				32000	16000	19000	1225	1940		19802	EG	
									standard			
									EG			
				max. possible:								
				41000			2 x 9000		32000			

vehicle dimensions**																											
Cabin	Standard tyre	Dimensions	Rim	S (R stat.)	C1	C2	C3	C	cv	D	dv	H	H1	N	N1	P	P1	Q	T	T1	U	Z	ØR	ØW	α	γ	β
AD-HR-TP	13R22.5	Ø1124x 320	22.5x9.00	521	1981	1831	--	1216	93	1180	64	3326	3233	80	--	371	701	311	1219	1166	2501	350	20900	22500	35°	29°	14°

OPTIONAL TYRES			
Types	Dimensions	Rim	S (Rstat.)
325/95R24	1228 x 325	24x8.5	568
395/85R20	1180 x 386	20x10	540
14R20	1238 x 370	20x10	564
315/80R22.5	1076 x 312	22.5x9.00	500
385/65R22.5	1072 x 389	22.5x11.75	496
365/85R20	1128 x 364	20x10.00	518

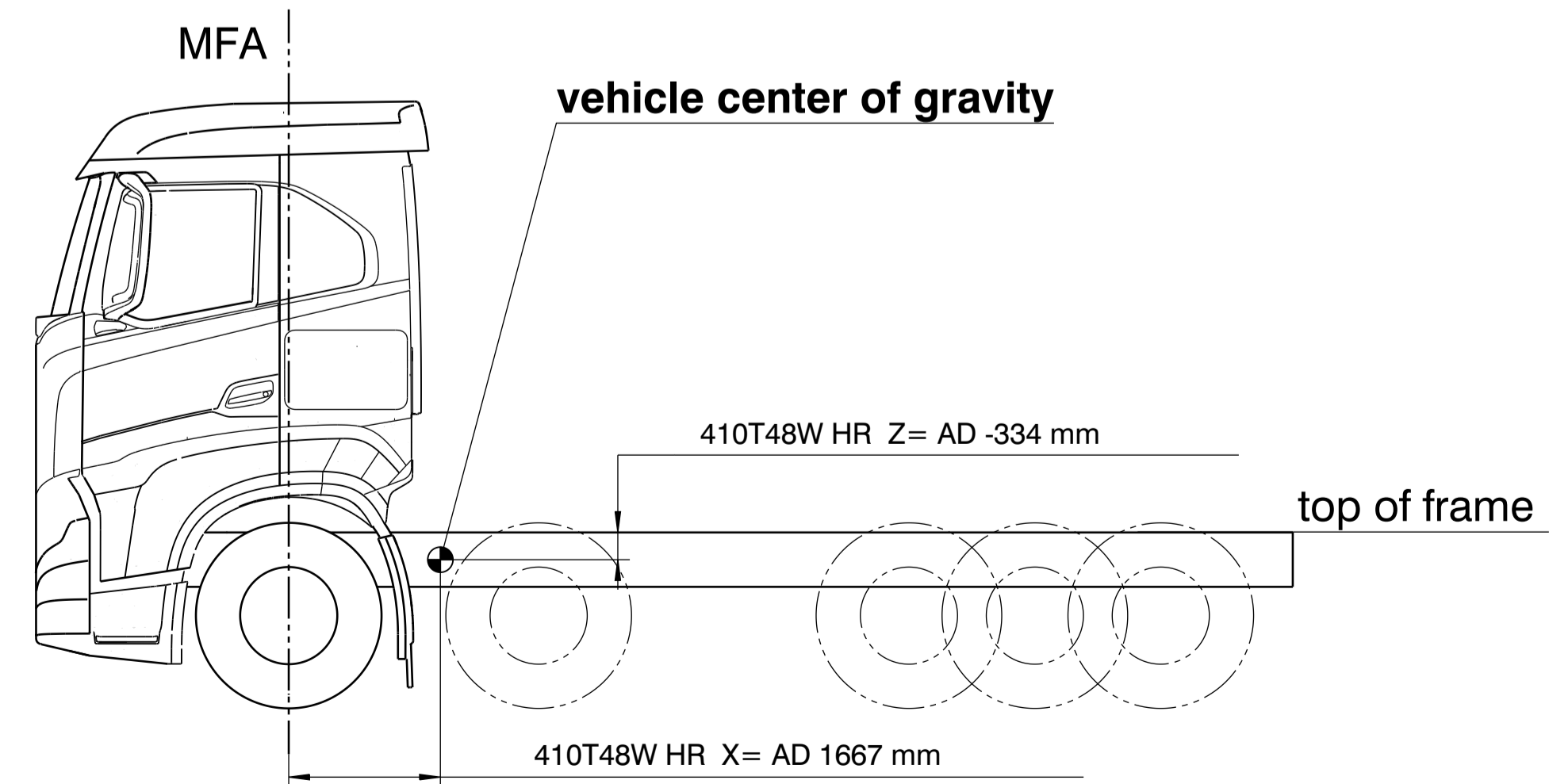

*Remarks for weights and dimensions:
Standard vehicle with driver, tool and accessory kit.
Fuel-tank 90% and urea-tank full.

** vehicle dimensions definition			
S	Tyre radius stat.	P	Clearance beneath the front axle
C1	Track of the front axle	P1	Clearance beneath the bumper
C2	Track of the drive axle	Q	Clearance beneath the rear axle
C3	Track of the trailing/leading axle	T	Height of frame end unladen
C	Frame height stat. at the front axle	T1	Height of frame end loaded (stat.)
cv	Rebound on the front axle (spring + tyre)	U	Width over tyres at the drive axle
D	Frame height stat. at the rear axle	Z	Distance tyre center at the drive axle
dv	Rebound on the rear axle (spring + tyre)	ØR	Turning circle tyre outer edge (curb to curb)
H	Vehicle height max. unladen	ØW	Turning circle (wall to wall)
H1	Vehicle height max. loaded (stat.)	α	Approach angle loaded (stat.)
N	Max. dynamic tyre movement	γ	Ramp angle loaded (stat.)
N1	Max. height of tyre lifted	β	Departure angle loaded (stat.)

This drawing complies with the standard vehicle configuration.
Design and technical drawing are subjected to changes.

All proprietary rights reserved by CNH Industrial N.V. and/or one of its subsidiaries. This drawing shall not be reproduced, or in any way utilized, for the manufacture of the component or unit herein illustrated and must not be released to other parties, without written consent of the proprietor. Any infringement will be legally pursued.

STANDARDS mentioned: General rules Iveco Std. 10-2999

vehicle drawing on sheet 1

Scale: 1:20	Material	Standards	Code No
CNH0 n° 0			
n° 0			
	Mass (kg): 0.000	Blank-No	
		Designation	Lexicon Code: 143320
Drawn by: Marra	Date: 30.09.2021	HEAVY TRUCK TECHNICAL DRAWING	
Checked by: Marra	Date: 30.09.2021		
Approved: Martinez, Ana	Department: E040	AD410T48W 8x8 T-Way OFF MY2019 E5 WB: 5020/1400	
Model: IVECO T-WAY AD		No: 5803039175 DB 55-9520	Sheet 2/2 A1
Origin:	Replaces:	Replaced by:	